

Distribution Equipment **SPEEDFAX**

Section 7 Panelboards

Contents

Sentron Panelboards – Features, Reference Guide	7/2
Panelboard Catalog Numbering System	7/5
P1 Feature Overview	7/3
Specifications	7/4
Main Lug Selection	7/7
Main or Subfeed Breakers	7/8
Branch Breaker Selection	7/9
Main Breaker Selection	7/10
Selection and Application	7/11-7/15
Modifications and Additions	7/16
Dimensions and Weights	7/17
Cross Reference	7/18
Type P2	
Selection and Application	7/19-7/22
Typical Catalog Numbers	7/23
Modifications	7/24-7/25
Connector Modifications	7/26-7/27
Dimensions	7/28
Kits and Accessories	7/29
Type S3	
Specifications	7/30
Circuit Breaker/Lighting and Distribution	7/31-7/32
Modifications and Additions	7/33-7/34
Type S5 (SPP6)	
Specifications	7/35
Main Lug and Main Breaker Selection	7/36
Branch Breakers	7/36
Modifications and Additions	7/37
Modifications, Additions, Replacements for Circuit Breakers	7/38
Type F2 (FPP6)	
Specifications and Fuse Types	7/39
Main Lug and Main Fusible	7/40
Modifications and Additions	7/41
Modifications, Additions, Replacements for Fusible Switches	7/42

Reference Guide



Circuit Breaker
Lighting Panelboard
Types P1



Circuit Breaker
Lighting Panelboard
Type P2



Circuit Breaker Power and
Distribution Panelboard
Type S5



Fusible Power
and Distribution Panelboard
Type F2

Features

Siemens offers a complete line of lighting and power distribution panelboards, along with a full range of fusible and circuit breaker devices. Also, two and three pole breakers are physically interchangeable with an equivalent number of one pole breakers.

Lighting Panels

General – P1/P2: Interiors have the ability to physically interchange two and three pole breakers with an equivalent number of one pole breakers. Panels come standard with connectors suitable for connection to copper or aluminum cable. Panel interiors have adjustment screws to provide easy alignment for flush mounted applications. The interior is provided with wing nuts for securing to box without tools. Removable end walls are standard and available blank and with KO's. Panelboard box has a separate CSA label and supplies wire bending and gutter requirements to meet CSA standards. Wiring gutters are completely free of any part of trim clamp to prevent damaging wire insulation. Deadfronts are provided with a flange for easy attachment of trim. Incoming cable lugs are grouped at one end to separate them from the load side cables. Individual circuit number button with an embossed number next to each breaker or provision are provided. The interior shall be provided with wing nuts for securing to box without tools. The panel trim may be surface or flush and is equipped with concealed hinges, flush lock and a holder for circuit directory card. Trim shall have two separate supports designed to engage the box flange to stabilize and secure the trim during installation. Trim screws are located behind the lockable door for tamper resistance.

Interior – Type P1: Interiors may be

completely factory-assembled. Interiors permit installation of feed-thru lugs or a bus fed subfeed circuit breaker, up to 600 amperes, without increasing the enclosure size. Interiors are convertible from main lug to main breaker with the addition of an appropriate field-installable kit. Interior are changeable from top to bottom feed and vice-versa, while maintaining readability of dead-front labeling. Main lugs up to 350 mcm are lay-in construction to facilitate connections. Neutral bussing is located adjacent to the breaker load terminals for easy wiring and shortest cable run possible.

Interior – Type P2: Interiors are completely factory-assembled. Incoming cable lugs are grouped at one end to separate them from the load side cables. For easy wiring and shortest cable run possible, load side neutral connection lugs to be split with each side taking 50% of load neutral connections.

Power Panels

General – S5/F2: Standard fronts are four piece for surface installations. Panels come standard with connectors suitable for connection to copper or aluminum cable. The interior is provided with wing nuts for securing to box without tools. Removable end walls are standard. Panelboard box has a separate CSA label and supplies wire bending and gutter requirements to meet the NEC and CSA standards.

Interior – S5/F2: Interiors are completely factory-assembled. Incoming cable lugs are grouped at one end to separate them from the load side cables. For easy wiring and shortest cable run possible, load side neutral connection lugs to be split with each side taking 50% of load neutral connections.

Application

Lighting:

Control centers for lighting and power circuits in commercial and industrial installations as well as residential where extensive electrical systems are involved.

Power and Distribution – Control centers for power and distribution circuits as well as service equipment in larger commercial and industrial installations.

Ratings

P1/P2: 1 phase, 3 wire, 3 phase, 3 or 4 wire; 120 through 600 Volts AC; 250 Volts DC; 125–600 amperes; main lug only, 50–600 amperes main breakers; 600 amperes maximum branch.

S5/F2: 1 phase, 3 wire; 3 phase, 3 or 4 wire; 120/240 through 600 Volts AC; 250 Volts DC; 400–1200 amperes; 1200 amperes maximum branch circuit breakers and 600 ampere maximum fusible switches.

Specifications: All panelboards are listed by Underwriters' Laboratories, Inc. Interiors are listed under File #E2269. Boxes and fronts are listed under file #E4016 & CSA File #LR93833

Standards: Interiors – UL 67, NEMA PB1 & CSA C22.2 No. 29 Enclosures – UL 50, NEMA 250 & CSA C22.2 No. 0.12

P1 Panelboards

P1 Feature Overview

Key Panelboard Features
Lighting and Appliance Applications
Power Panelboard Applications
Convertible From Top Feed to Bottom Feed and Vice Versa
Change From Main Lug to Main Breaker or Add Sub-Feed Without Changing Enclosure Size
Space-Saving, Horizontally Mounted Main Breaker Through 250 Amps
Short-Circuit Rating Label Giving Performance Level
Standard Aluminum Ground Bus
Blank End-Walls Standard
Bolted Current-Carrying Parts
Split Neutral
Connection Accessible From Front
Screw-Type Mechanical Lugs
Time-Reducing Wing Nuts to Secure Interior Without Tools
200 Ampere Rated Branch Breaker Connector
Main and Branch Devices Connected With Case-Hardened
Flush Lock, Concealed Door Hinges/Trim Screws
Symmetrical Interior Mounting Studs to Eliminate Upside-Down Mounting of Box
Jacking Screw Interior Adjustment
Shallow Depth
Optional Compression Lugs
Service Entrance Barrier
Single and Double Drip Shield Kits

A product of outstanding quality, the current family of panelboard designs represents the high level of engineering innovation expected from Siemens. Additional strength has been added to an already rugged and durable panelboard family. At the same time, many models have a trimmed exterior size, have added flexibility and are easier to install. These newer designs simplify wiring and reduce material requirements, saving additional installation time.

The lighting panel design still features the Fas-Latch trim that is so popular with installers, the jacking screw system that permits adjustments even after wiring has been installed, and other features such as exclusive split neutral. Many panelboards have the capability of mixing and matching breakers of different sizes and ratings, or changing from main lug to main breaker, or adding sub-feed breakers without changing box size.

The complete family of panelboards from Siemens employs numerous features – all industry-leading, many exclusive. Note the following, all found in the innovative P1 lighting panelboards:

- Symmetrical interiors – no top or bottom! To change from top to bottom (or vice versa), simply invert the interior. The deadfront labeling is always right-side up.
- First in the industry ratings of 125A/250A main lug and main breaker.
- Field convertible from main lug to main breaker and vice versa, with no increase in enclosure height.
- Field addability of feed-thru lugs or sub-feed circuit breaker without increasing enclosure size.
- Neutral system is field upgradeable to 200% capacity – another industry first.
- Three circuit sizes (18, 30, 42) mean only three box heights, regardless of main configuration through 250 amps and an additional (18, 30, 42) circuit version available at 400 amps.
- Suitable for use as service entrance given compliance with CEC.
- Bonding provisions are shipped with each panel.
- 240V and 600Y/347V versions utilize identical boxes and fronts.



Class CTL Panelboards

Class CTL panelboards incorporate physical features which, in conjunction with the physical size, configuration, or other means provided in Class CTL circuit breakers, are designed to prevent the installation of more overcurrent protective poles than that number for which the device is designed and rated.

Standards

CSA: 22.2 No.29 - M1989. (File # LR93833)

CEC: 2002

NEC: 1998

NEMA: PB1

UL: 67 and 50. Listed by Underwriter's Laboratories, Inc., under "Panelboards" File #E2269, and #E4016. Meets Federal Specification W-P-115c dated June 8, 1996, for Type 1, Class 1.

Service Entrance Equipment

When a panelboard is used as service entrance equipment, it must be supplied with the appropriate CSA certification and labelling. Please consult CSA, CEC and local inspection authorities for specification and installation guidelines.

Panelboards must be identified as "Service Entrance" at the time of order entry.

Also panels must include a connector for bonding and grounding neutral conductor.

Integrated Equipment Short Circuit Rating (Series Ratings)

The term "Integrated Equipment Short Circuit Rating" refers to the application of series connected circuit breakers in combination that allows some breakers to have lower individual interrupting ratings than the available fault current. This is permitted as long as the series combination has been tested and certified by CSA. "Series Rated" must be identified at the time of order entry.

Lighting and Distribution Panels – Type P1

- Interiors have the ability to physically interchange two- and three-pole breakers with an equivalent number of one-pole breakers.
- Panels come standard with connectors suitable for connection to copper or aluminum cable.
- Panels are labeled as "suitable for use as service entrance equipment."
- Panel interiors have adjustment screws to provide easy alignment for flush mounted applications.

- Removable end-walls are standard and available blank or with KO's.
- Panelboard box has a separate CSA and UL label and provides wire bending and gutter requirements to meet the CEC, NEC, CSA and UL standards.
- Wiring gutters are completely free of any part of trim clamp to prevent damaging wire insulation.
- Deadfronts are provided with a flange for easy attachment of trim.
- Incoming cable lugs are grouped at one end to separate them from the load side cables.
- Individual circuit number button, as well as an embossed number next to each breaker or provision, are provided
- The interior shall be provided with wing nuts for securing to box without tools.
- The panel trim may be surface or flush and is equipped with concealed hinges, flush lock and a holder for circuit directory card. Trims are fabricated from code gauge steel and finished ANSI 61.
- Trim shall have two separate supports designed to engage the box flange to stabilize and secure the trim during installation.
- Trim screws to be located behind the lockable door for tamper resistance.

Interior – Type P1

- Interiors may be completely factory-assembled.
- Sizing of conductor is in accordance with CSA and UL.
- Interiors permit installation of feed-thru lugs or a bus fed sub-feed circuit breaker, up to 250 amperes, without increasing the enclosure size.
- Interiors are convertible from main lug to main breaker with the addition of an appropriate field-installable kit.
- Interiors are changeable from top to bottom feed and vice versa, while maintaining readability of deadfront labeling.
- Main lugs up to 350 Kcmil are lay-in construction to facilitate connections.
- Neutral bussing is located adjacent to the breaker load terminals for easy wiring and shortest cable run possible.

Catalogue Numbering System

SELECTION

Reference Guide

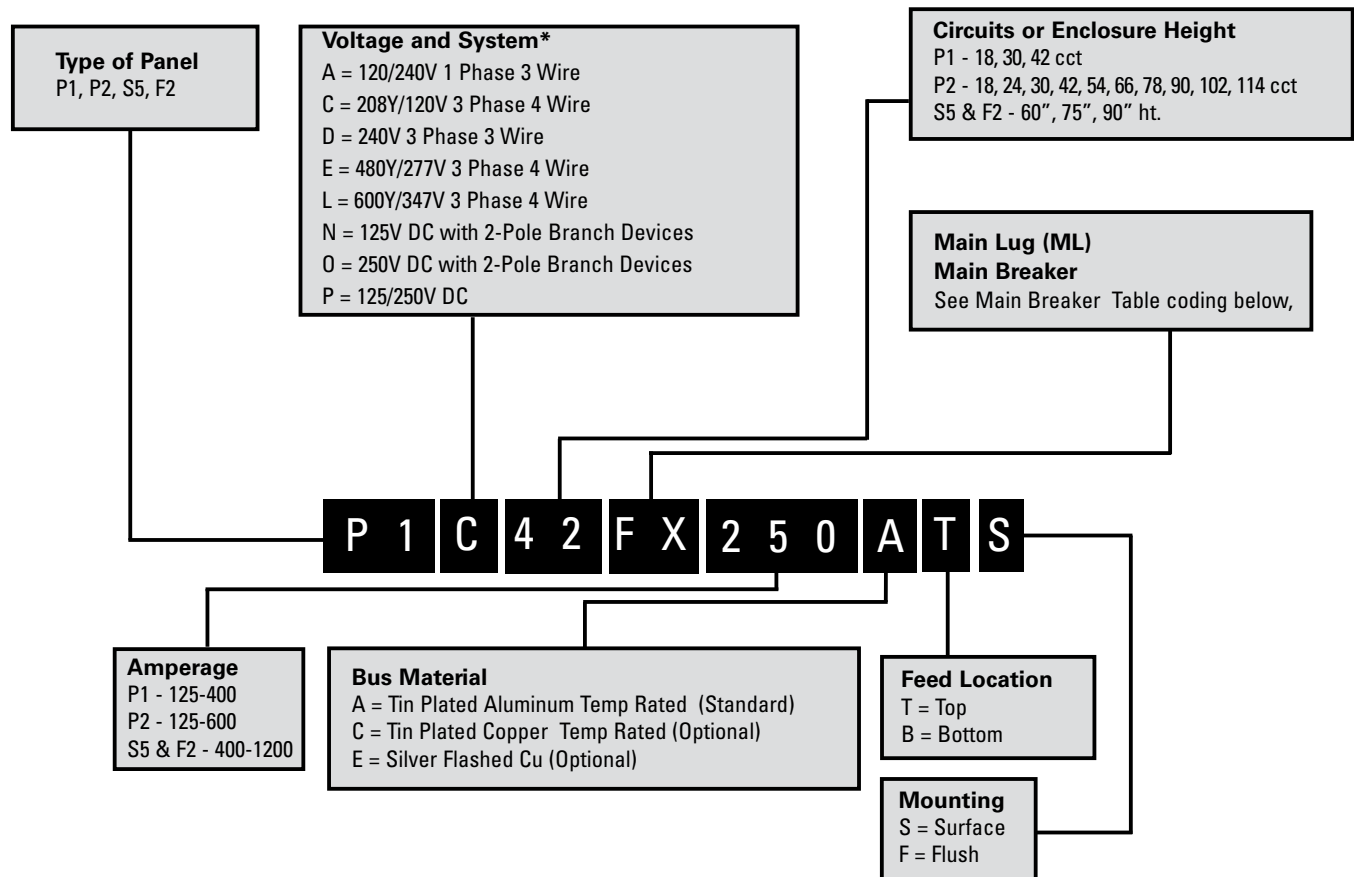

Main Breaker Coding

(Breaker Type) Code

(BL) BL, (BLH) LH, (HBL) HL, (BQD6) BD, (ED4) E4, (ED6) E6, (HED4) H4, (HED6) H6, (QJ2) QJ, (QJH2) QH, (QJ2-H) Q2, (FXD6) FX, (HFD6) HF, (JD6) J6, (JXD6) JX, (HJD6) HJ, (CJD6) CJ, (SJD6) SJ, (LXD6) LX, (LD6) L6, (HLD6) HL, (MD6) M6, (HMD6) HM, (CMD6) CM, (SMD6) SM, (ND6) N6, (HND6) HN, (CND6) CN, (SND6) SN

* Other voltages available. Please contact your local Siemens representative.

Distributor Stock Panelboards

SELECTION

Type P1 Panelboards

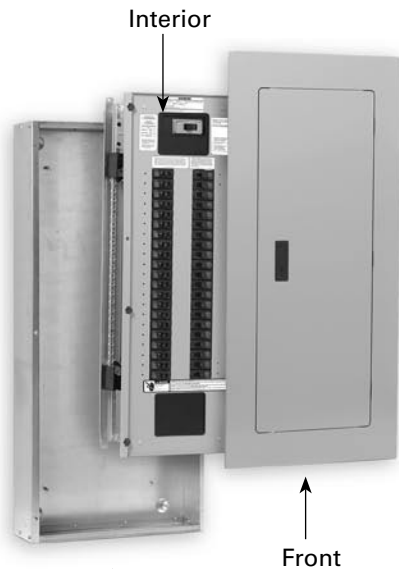

Interiors Only – Less Branch Breakers				Boxes			Fronts	
Amp Rating Mains	Max No. of Poles	Interiors Convertible Mains	Interiors Main Lug	Height (in.)	Type 1	Type 3R/12	Surface	Flush

1 Ø 3 Wire

120/240V

250	18	P1A18MC250A	P1A18ML250A	32	B32	WP32	S32B	F32B
	30	P1A30MC250A	P1A30ML250A	38	B38	WP38	S38B	F38B
	42	P1A42MC250A	P1A42ML250A	44	B44	WP44	S44B	F44B
400	18	P1A18MC400A	P1A18ML400A	56	B56	WP56	S56B	F56B
	30	P1A30MC400A	P1A30ML400A	62	B62	WP62	S62B	F62B
	42	P1A42MC400A	P1A42ML400A	68	B68	WP68	S68B	F68B
250	18	P1A18MC250C	P1A18ML250C	32	B32	WP32	S32B	F32B
	30	P1A30MC250C	P1A30ML250C	38	B38	WP38	S38B	F38B
	42	P1A42MC250C	P1A42ML250C	44	B44	WP44	S44B	F44B
400	18	P1A18MC400C	P1A18ML400C	56	B56	WP56	S56B	F56B
	30	P1A30MC400C	P1A30ML400C	62	B62	WP62	S62B	F62B
	42	P1A42MC400C	P1A42ML400C	68	B68	WP68	S68B	F68B

3 Ø 4 Wire

208Y/120V

250	18	P1C18MC250A	P1C18ML250A	32	B32	WP32	S32B	F32B
	30	P1C30MC250A	P1C30ML250A	38	B38	WP38	S38B	F38B
	42	P1C42MC250A	P1C42ML250A	44	B44	WP44	S44B	F44B
400	18	P1C18MC400A	P1C18ML400A	56	B56	WP56	S56B	F56B
	30	P1C30MC400A	P1C30ML400A	62	B62	WP62	S62B	F62B
	42	P1C42MC400A	P1C42ML400A	68	B68	WP68	S68B	F68B
250	18	P1C18MC250C	P1C18ML250C	32	B32	WP32	S32B	F32B
	30	P1C30MC250C	P1C30ML250C	38	B38	WP38	S38B	F38B
	42	P1C42MC250C	P1C42ML250C	44	B44	WP44	S44B	F44B
400	18	P1C18MC400C	P1C18ML400C	56	B56	WP56	S56B	F56B
	30	P1C30MC400C	P1C30ML400C	62	B62	WP62	S62B	F62B
	42	P1C42MC400C	P1C42ML400C	68	B68	WP68	S68B	F68B

3 Ø 4 Wire

600Y/347V

250	18	P1L18MC250A	P1L18ML250A	32	B32	WP32	S32B	F32B
	30	P1L30MC250A	P1L30ML250A	38	B38	WP38	S38B	F38B
	42	P1L42MC250A	P1L42ML250A	44	B44	WP44	S44B	F44B
400	18	P1L18MC400A	P1L18ML400A	56	B56	WP56	S56B	F56B
	30	P1L30MC400A	P1L30ML400A	62	B62	WP62	S62B	F62B
	42	P1L42MC400A	P1L42ML400A	68	B68	WP68	S68B	F68B
250	18	P1L18MC250C	P1L18ML250C	32	B32	WP32	S32B	F32B
	30	P1L30MC250C	P1L30ML250C	38	B38	WP38	S38B	F38B
	42	P1L42MC250C	P1L42ML250C	44	B44	WP44	S44B	F44B
400	18	P1L18MC400C	P1L18ML400C	56	B56	WP56	S56B	F56B
	30	P1L30MC400C	P1L30ML400C	62	B62	WP62	S62B	F62B
	42	P1L42MC400C	P1L42ML400C	68	B68	WP68	S68B	F68B

Type P1 Panelboards

Lug Kits – Main or Feed-Thru

Amp Rating	Material	Wire Range	Service	Catalog No.
250	Al	(1) #6 AWG - 350 Kcmil (Cu or Al)	1 Phase	MLKA1
		(1) #6 AWG - 350 Kcmil (Cu or Al)	3 Phase	MLKA3
	Cu	(1) #6 AWG - 350 Kcmil (Cu or Al)	1 Phase	MLKC1
		(1) #6 AWG - 350 Kcmil (Cu or Al)	3 Phase	MLKC3
400	Al	(2) 3/0 AWG - 250 Kcmil / (1) 600 Kcmil	1 Phase	4MLKA1
		(2) 3/0 AWG - 250 Kcmil / (1) 600 Kcmil	3 Phase	4MLKA3
	Cu	(2) 3/0 AWG - 250 Kcmil / (1) 600 Kcmil	1 Phase	4MLKC1
		(2) 3/0 AWG - 250 Kcmil / (1) 600 Kcmil	3 Phase	4MLKC3

Miscellaneous Replacement Parts (continued)

Catalog No.	Description
12-A1801-1	4'x4' Filler Plate for Main & Feedthru
FPLK2	2 Locks with Key
JCK24	24 Trim Screws & Clips
10FLHx2	BL Lineside Screws - 1 Bag of 200

Copper Neutral Lug Kits – 250A

No. of Circuits	Description	Catalog No.
18	2 Branch Neutral Strips, 1 Main Neutral Lug, Hardware	CNLK18
30	2 Branch Neutral Strips, 1 Main Neutral Lug, Hardware	CNLK30
42	2 Branch Neutral Strips, 1 Main Neutral Lug, Hardware	CNLK42

200% Neutral Lug Kits – 250A

No. of Circuits	Description	Catalog No.
18	2 Branch Neutral Strips, 2 Main Neutral Lug, Hardware	2NLK18
30	2 Branch Neutral Strips, 2 Main Neutral Lug, Hardware	2NLK30
42	2 Branch Neutral Strips, 2 Main Neutral Lug, Hardware	2NLK42

200% Neutral Lug Kits – 400A

No. of Circuits	Description	Catalog No.
18	2 Branch Neutral Strips, 4 Main Neutral Lug, Hardware	42NLK18
30	2 Branch Neutral Strips, 4 Main Neutral Lug, Hardware	42NLK30
42	2 Branch Neutral Strips, 4 Main Neutral Lug, Hardware	42NLK42

Miscellaneous Replacement Parts

Catalog No.	Description
EGK	Al Ground Bus 44 Connections
BK1	Bonding Kit (250A Max.)
BK4	Bonding Kit (400A Max.)
IMK1	Interior Adjusting Kit
MCHK	Metallic Directory Card Holder
NBK03	Number Strips 1-42
11-1824-01	Directory Card Holder
12-1110-01	Directory Card
11-1056-01	NEMA Instruction Book
MHKP1	Truck Kit for P1



PANELBOARDS

Distributor Stock Panelboards

SELECTION

Type P1 Panelboards

Breaker Mounting Kits – Main or Subfeed (Breaker not included)

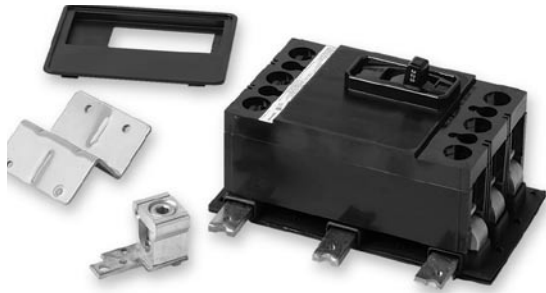

MBKQJ3
(Breaker not included)

Amp Rating	Main	Sub-feed	Breaker Frames	Service	Catalog No.
100	Yes	Yes	BL, BLH, HBL	1 Phase	MBKBL1
				3 Phase	MBKBL3
100	Yes	Yes	BQD6	1 Phase	MBKBC1
				3 Phase	MBKBC3
125	Yes	Yes	ED2, ED4, ED6, HED4	1 Phase	MBKED1
				3 Phase	MBKED3
225	Yes	Yes	QJ2, QJH2, QJ2-H	1 Phase	MBKQJ1
				3 Phase	MBKQJ3
250	Yes	Yes	FXD6, FD6, HFD6	1 Phase	MBKFD1
				3 Phase	MBKFD3
400	Yes	No	JD6, JXD6, HJD6, HHJD6	1 Phase	MBKJD1
				3 Phase	MBKJD3



MBKFD3
(Breaker not included)

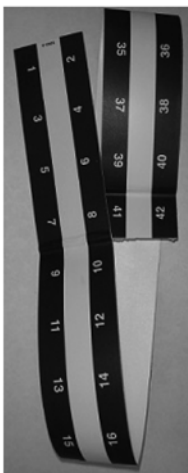

NBK03 **NBK03-UL**
Both number strips are supplied in P1

1	8	15	22	29	36
2	9	16	23	30	37
3	10	17	24	31	38
4	11	18	25	32	39
5	12	19	26	33	40
6	13	20	27	34	41
7	14	21	28	35	42

Miscellaneous Accessories

Catalog No.	Description
NBK04	Number Strips 43-84
NBK05	Number Strips 85-126
NBK06	Number Strips 127-168
ECGK	Cu Ground Bus 44 Connections
IGK	Insulated Al Ground Bus
ICGK	Insulated Cu Ground Bus
EWK1	End-Wall Kit with Knockouts (20"W x 5.75" DP)
QF3 - UL	Filler Plate
SDKN	Dripshield Kit (20"W x 5.75" DP)

Distributor Stock Panelboards

SELECTION

Circuit Breaker / Lighting and Distribution

Branch Breakers Selection for P1

Selection Guide

1. Select breaker type.
2. Select required amperage.
3. Select number of poles.
4. Select branch breaker catalog numbers.
5. Select ground bus and filler plates. (See replacement parts & accessories on page 5 & 6.)

BL Branch Breakers – 10,000A IR

Amp Rating	1-Pole 120/240V	2-Pole 120/240V	2-Pole 240V	3-Pole 240V
15	B115	B215	B215R	B315
20	B120	B220	B220R	B320
25	B125	B225	B225R	B325
30	B130	B230	B230R	B330
40	B140	B240	B240R	B340
50	B150	B250	B250R	B350
60	B160	B260	B260R	B360
70	B170	B270	B270R	B370
80	–	B280	B280R	B380
90	–	B290	B290R	B390
100	–	B2100	B2100R	B3100

BLH Branch Breakers – 22,000A IR

Amp Rating	1-Pole 120/240V	2-Pole 120/240V	3-Pole 240V
15	B115H	B215H	B315H
20	B120H	B220H	B320H
25	B125H	B225H	B325H
30	B130H	B230H	B330H
40	B140H	B240H	B340H
50	B150H	B250H	B350H
60	B160H	B260H	B360H
70	B170H	B270H	B370H
80	–	B280H	B380H
90	–	B290H	B390H
100	–	B2100H	B3100H

HBL Branch Breakers – 65,000A IR

Amp Rating	1-Pole 120/240V	2-Pole 120/240V	3-Pole 240V
15	B115HH	B215HH	B315HH
20	B120HH	B220HH	B320HH
30	B130HH	B230HH	B330HH
40	B140HH	B240HH	B340HH
50	B150HH	B250HH	B350HH
60	–	B260HH	B360HH
70	–	B270HH	B370HH
80	–	B280HH	B380HH
90	–	B290HH	B390HH
100	–	B2100HH	B3100HH

BQD6 Branch Breakers – 10,000A IR Max

Amp Rating	1-Pole 347V	2-Pole 600Y/347V	3-Pole 600Y/347V
15	BQD6115	BQD6215	BQD6315
20	BQD6120	BQD6220	BQD6320
25	BQD6125	BQD6225	BQD6325
30	BQD6130	BQD6230	BQD6330
35	BQD6135	BQD6235	BQD6335
40	BQD6140	BQD6240	BQD6340
45	BQD6145	BQD6245	BQD6345
50	BQD6150	BQD6250	BQD6350
60	BQD6160	BQD6260	BQD6360
70	BQD6170	BQD6270	BQD6370

For detailed circuit breaker information please consult Section #6.



Main Breaker Selection (Breaker Kit)

Catalogue No.	Description	Ratings 240V	Ratings 480V	Ratings 600V
MBKBL12100	Kit with 2-Pole BL 100A Breaker	10KA	–	–
MBKBL33125	Kit with 3-Pole BL 125A Breaker	10KA	–	–
MBKBC12100	Kit with 2-Pole BQD6 100A Breaker	65KA	14KA	10KA
MBKBC33100	Kit with 3-Pole BQD6 100A Breaker	65KA	14KA	10KA
MBKED33100	Kit with 3-Pole ED6 100A Breaker	65KA	25KA	18KA
MBKED33125	Kit with 3-Pole ED6 125A Breaker	65KA	25KA	18KA
MBKQJ12125	Kit with 2-Pole QJ2 125A Breaker	10KA	–	–
MBKQJ33150	Kit with 3-Pole QJ2 150A Breaker	10KA	–	–
MBKQJ33200	Kit with 3-Pole QJ2 200A Breaker	10KA	–	–
MBKQJ33225	Kit with 3-Pole QJ2 225A Breaker	10KA	–	–
MBKFD33225	Kit with 3-Pole FXD6 225A Breaker	65KA	35KA	18KA
MBKFD33250	Kit with 3-Pole FXD6 250A Breaker	65KA	35KA	18KA
MBKJD33400	Kit with 3-Pole JXD6 400A Breaker	65KA	35KA	25KA

Other Breaker kits available. Please contact your local Siemens representative.



MBKFD33250
(Breaker included)



PANELBOARDS

Factory Assembled Panelboards

SELECTION

Selection and Application

3 Easy Steps for Selecting a Siemens P1 Panelboard

Step 1

– Determine voltage, system, amperage and interrupting rating of branch devices, and modifications if any.

Example for standard lighting panelboard:

Amperage	250A
Voltage	208Y/120V
System	3Ø4W
Main	Main Lug
Branches	10K AIR, 42-20/1
Modifications	None
Feed Location	Top
Mounting	Surface

Step 2

– Create a catalog number by following the Panelboard Catalog Numbering System on page 7/6.

1-P1C42ML250ATS
42-20/1 BL

Step 3

– Select enclosure size by the number of circuits as shown in the panelboard main lugs only chart on page 7/8.

1-P1C42ML250ATS
42-20/1 BL
Box size – 44" high

A unique feature of the P1 panels is that they can accommodate either feed-thru lugs or one sub-feed circuit breaker (up to 250A) without any addition in box height. For our example changing the branch circuits to

39-20/1 and 1-125/3, we have the following:

1-P1C42ML250ATS
39-20/1 BL
1-125/3 QJ2
3-Spaces
Box size – 44" high

The QJ2 sub-feed was selected from the table of sub-feed breakers on page 7/9. The box height remains the same.

Circuit Breaker / Lighting & Distribution

**600Y/347 Vac Max.
250 Vdc Max.
400 Ampere Mains
250 Ampere Maximum Subfeed Breaker
CSA/UL Short Circuit Rating –
200,000A IR Maximum *
Breaker Symmetrical
Interrupting Capacity**

Main Breakers

For main breaker selection please refer to chart on page 7/11. Connector ranges indicated do not apply to all main breaker types. Refer to molded case circuit breaker standard pressure wire connectors.

Boxes

20" wide, 5.75" deep (400A max)
End-walls are blank as standard.
End-walls with knockouts are available.

Weight – Approximate

Total panelboard weight when filled with a normal quantity of breakers and accessories is about 3 lbs. per inch of box height.

Main Breaker Panel Connectors

Amp Rating	Connectors Suitable for Cu or Al
100	(1) - #14 - 1/0 AWG
125	(1) - #4 - 1/0 AWG
225	(1) - #4 AWG - 300 Kcmil
250	(1) - #4/0 AWG - 350 Kcmil Al
	(1) - #6/0 AWG - 350 Kcmil Cu
400	(2) - #4/0 AWG - 250 Kcmil
	(1) - #4/0 AWG - 500 Kcmil

Gutters (Wiring Space)

Breaker Type	Main Lug	Main Breaker	Branch Breaker
125/250A	10.5"	N/A	N/A
400A	25.5"	N/A	N/A
BL, BLH, HBL, BQD6	N/A	8.5"	6.375"
QJ, QJH2, QJ2H	N/A	6.5"	6.5"
ED4, ED6, HED4	N/A	6.125"	6.125"
FXD6, FD6, HFD6	N/A	5.25"	5.25"
JXD6, ¹ JD6, ¹ HJD6 ¹	N/A	15.0"	–

¹ 400A main breaker is vertical mount

Main Lug Connectors

Amp Rating	Connectors Suitable for Cu or Al
125	(1) - #6 AWG - 350 Kcmil
250	(1) - #6 AWG - 350 Kcmil
400	(2) - #4/0 AWG - 250 Kcmil
	(1) - #4/0 AWG - 600 Kcmil

Box Material Gauge

Width	Height	Gauge Steel
20" (250A Max)	32, 38, 44	#16
20" (Above 250A)	56, 62, 68	#16

Trim Material Gauge

Width	Height	Gauge Steel
20" (250A Max)	32, 38, 44	#14
20" (Above 250A)	56, 62, 68	#14

* IR Rating will depend on the type of main breaker applied or if main breaker is "Series Rated" with an up stream protective device (circuit breaker or fuse).

Factory Assembled Panelboards

SELECTION

Selection and Application

Main Lugs Only

Max Panel Amp Rating	Max 1-Pole Circuits	Box Ht. (in.)	Catalog No.			
			208Y/120V 3Ø4W	120/240V 1Ø3W	480Y/277V 3Ø4W	600Y/347V 3Ø4W
125	18	32	P1C18ML125ATS	P1A18ML125ATS	P1E18ML125ATS	P1L18ML125ATS
	30	38	P1C30ML125ATS	P1A30ML125ATS	P1E30ML125ATS	P1L30ML125ATS
	42	44	P1C42ML125ATS	P1A42ML125ATS	P1E42ML125ATS	P1L42ML125ATS
250	18	32	P1C18ML250ATS	P1A18ML250ATS	P1E18ML250ATS	P1L18ML250ATS
	30	38	P1C30ML250ATS	P1A30ML250ATS	P1E30ML250ATS	P1L30ML250ATS
	42	44	P1C42ML250ATS	P1A42ML250ATS	P1E42ML250ATS	P1L42ML250ATS
400	18	56	P1C18ML400ATS	P1A18ML400ATS	P1E18ML400ATS	P1L18ML400ATS
	30	62	P1C30ML400ATS	P1A30ML400ATS	P1E30ML400ATS	P1L30ML400ATS
	42	68	P1C42ML400ATS	P1A42ML400ATS	P1E42ML400ATS	P1L42ML400ATS

Aluminum Bus, Top Fed and Surface Mounted

Main Circuit Breaker

100	18	32	P1C18BL100ATS	P1A18BL100ATS	P1E18BD100ATS	P1L18BD100ATS
	30	38	P1C30BL100ATS	P1A30BL100ATS	P1E30BD100ATS	P1L30BD100ATS
	42	44	P1C42BL100ATS	P1A42BL100ATS	P1E42BD100ATS	P1L42BD100ATS
125	18	32	P1C18E2125ATS	P1A18E2125ATS	P1E18E6125ATS	P1L18E6125ATS
	30	38	P1C30E2125ATS	P1A30E2125ATS	P1E30E6125ATS	P1L30E6125ATS
	42	44	P1C42E2125ATS	P1A42E2125ATS	P1E42E6125ATS	P1L42E6125ATS
225	18	32	P1C18QJ225ATS	P1A18QJ225ATS	P1E18FX225ATS	P1L18FX225ATS
	30	38	P1C30QJ225ATS	P1A30QJ225ATS	P1E30FX225ATS	P1L30FX225ATS
	42	44	P1C42QJ225ATS	P1A42QJ225ATS	P1E42FX225ATS	P1L42FX225ATS
250	18	32	P1C18FX250ATS	P1A18FX250ATS	P1E18FX250ATS	P1L18FX250ATS
	30	38	P1C30FX250ATS	P1A30FX250ATS	P1E30FX250ATS	P1L30FX250ATS
	42	44	P1C42FX250ATS	P1A42FX250ATS	P1E42FX250ATS	P1L42FX250ATS
400	18	56	P1C18JX400ATS	P1A18JX400ATS	P1E18JX400ATS	P1L18JX400ATS
	30	62	P1C30JX400ATS	P1A30JX400ATS	P1E30JX400ATS	P1L30JX400ATS
	42	68	P1C42JX400ATS	P1A42JX400ATS	P1E42JX400ATS	P1L42JX400ATS

Aluminum Bus, Top Fed and Surface Mounted

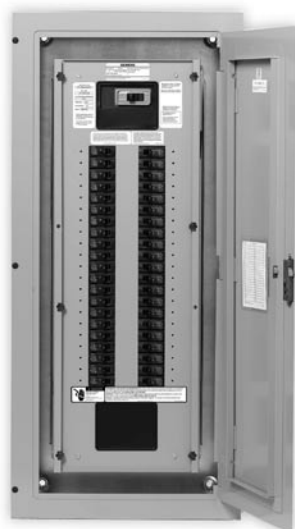

Factory Assembled Panelboards

SELECTION

Selection and Application - Type P1

Main Breaker Selection

Amp Rating	Breaker Type	Max. Interrupting Rating (kA)			Catalog No.	Available Trip Values
		240V	480Y/277V	600Y/347V		
100	BL	10	—	—	BL	30, 40, 50, 60, 70, 80, 90, 100
	BLH	22	—	—	LH	30, 40, 50, 60, 70, 80, 90, 100
	HBL	65	—	—	HL	30, 40, 50, 60, 70, 80, 90, 100
	ED2	10	—	—	E2	30, 40, 50, 60, 70, 80, 90, 100
	BQD6	65	14	10	BD	30, 40, 50, 60, 70,
125	ED4	65	18	—	E4	30, 40, 50, 60, 70, 80, 90, 100, 110, 125
	ED6	65	25	18	E6	30, 40, 50, 60, 70, 80, 90, 100, 110, 125
	HED4	100	42	—	H4	30, 40, 50, 60, 70, 80, 90, 100, 110, 125
225	QJ2	10	—	—	QJ	60, 70, 80, 90, 100, 110, 125, 150, 175, 200, 225
	QJH2	22	—	—	QH	60, 70, 80, 90, 100, 110, 125, 150, 175, 200, 225
	QJ2-H	42	—	—	Q2	60, 70, 80, 90, 100, 110, 125, 150, 175, 200, 225
	FD6	65	35	18	F6	60, 70, 80, 90, 100, 110, 125, 150, 175, 200, 225
	FXD6	65	35	18	FX	70, 80, 90, 100, 110, 125, 150, 175, 200, 225
	HFD6	100	65	25	HF	70, 80, 90, 100, 110, 125, 150, 175, 200, 225
250	FXD6	65	35	18	FX	70, 80, 90, 100, 110, 125, 150, 175, 200, 225, 250
	FD6	65	35	18	F6	60, 70, 80, 90, 100, 110, 125, 150, 175, 200, 225, 250
	HFD6	100	65	25	HF	70, 80, 90, 100, 110, 125, 150, 175, 200, 225, 250
400	JXD6	65	35	25	JX	200, 225, 250, 300, 350, 400
	JD6	65	35	25	J6	200, 225, 250, 300, 350, 400
	HJD6	100	65	35	HJ	200, 225, 250, 300, 350, 400
	HHJD6	200	100	50	HH	200, 225, 250, 300, 350, 400

Branch Breaker Selection

Breaker Frame	Amp Rating	No. of Poles	Max. Interrupting Rating (kA)		
			240V Max	480Y/277V/600Y/347V	
BL	15-70	1	10	—	—
	15-100	2, 3		—	—
BLH	15-70	1	22	—	—
	15-100	2, 3		—	—
HBL	15-50	1	65	—	—
	15-70	2		—	—
BLF	15-30	1	10	—	—
	15-60	2		—	—
BLHF	15-30	1	22	—	—
	15-60	2		—	—
BGL	15-30	2, 3	10	—	—
BLE	15-30	1	10	—	—
	15-60	2		—	—
BQD6	15-70	1, 2, 3	65	14	10

For detailed circuit breaker information please consult Section #6.

For "Series Rating", tested combinations please consult the Siemens Series Rated Combination Guide. # 0.5_10/01_AIS_1198

PANELBOARDS

Factory Assembled Panelboards

SELECTION

Selection and Application

**400 Amps Max.
600Y/347 Vac Max.
200 KAIC Rating Max.***

P1 panelboards are pre-engineered to accept the most common modifications without increasing box height. All P1 panelboards have space built-in to accept either feed-thru lugs (equal to the main rating) or a minimum of one subfeed circuit breaker up to 250 amps.



SubFeed Breakers ^{1,2}

Breaker Type	No. of Poles	Amp Rating	Max. Interrupting Rating (kA)		
			240V Max	480Y/277V	600Y/347V
ED2	2, 3	15-100	10	—	—
ED4	2, 3	15-125	65	18	—
ED6	2, 3	15-125	65	25	18
HED4	2, 3	15-125	100	42	—
QJ2	2, 3	60-225	10	—	—
QJH2	2, 3	60-225	22	—	—
QJ2-H	2, 3	60-225	42	—	—
FXD6, FD6	2, 3	70-250	65	35	18
HFD6, HFXD6	2, 3	70-250	100	65	25

¹ Please consult CSA, CEC, and local inspection authorities for specification and installation guidelines.

² No increase in box height. Space is already built into P1 panel.

Modifications

When required, special constructions or additions to standard panelboards may be specified for factory-assembled panelboards.

- | | |
|---|--|
| <p>A Type 3R/12
Gasketed Trim
Painted Box</p> <p>B Hinged Front</p> <p>C Door in Door Front</p> <p>D Metal Card Holder
Lock</p> <p>E Nameplate
Aluminum Equipment
Ground Bar
Copper Equipment Ground
Bar
Insulated Equipment</p> | <p>F Compression Lugs
Copper Lugs
200% Neutral
Copper Main Bus</p> <p>G Handle Blocking Device</p> <p>H Padlocking Device</p> |
|---|--|

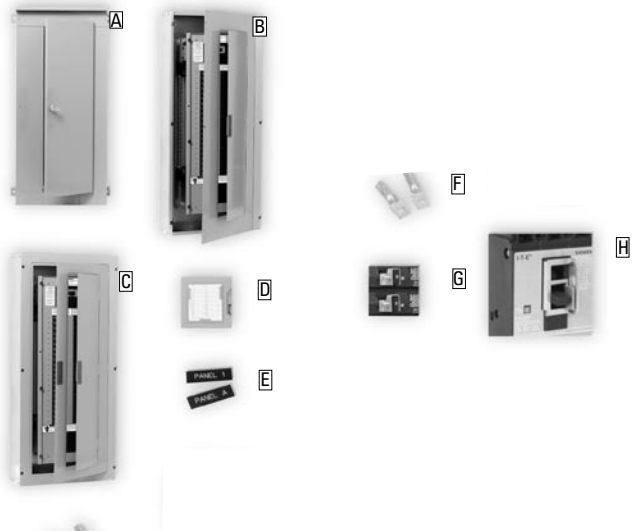

* IR Rating will depend on the type of main breaker applied or if main breaker is "Series Rated" with an up stream protective device (circuit breaker or fuse).

Factory Assembled Panelboards

SELECTION

Selection and Applications - Type P1

When required, special construction or additions to standard panelboards may be specified for all **Factory-Assembled** Lighting and Distribution Panelboards. Listed below are many of those available for P1 panelboards. In no case do these apply to **Narrow** (Column) Width Lighting Panelboards or **Unassembled** Panelboards.

200% Capacity Neutral*
Copper Branch Neutral Lugs
Copper Main Lugs 125A
Copper Main Lugs 250A
Compression Lugs

Miscellaneous

2. Gasketed — (No Knockouts)

Type 1 Gasketed (Gasket Between Box and Trim).

3. Painted Boxes

Standard Colour (ASA61) – Box only.

4. Special Front and Door Arrangements

See items B and D (page 7/15) for standard front modifications. Consult local sales office for others.

5. Front and Door Accessories

Please see page 7/15.

6. Service Entrance Label

Type P1 Panelboards are factory labeled suitable for use as service entrance equipment. For regulations governing this feature, please consult CEC, CSA, or local electrical authorities.

7. Grounding of Panelboards

(Add to Base Price)

Ground Bars are shipped with the panel interior factory mounted.

- Non-Insulated Equipment Ground Bar – Standard. EGK
- Copper Non-Insulated Ground Bar. ECGK
- Al Insulated Equipment Ground Bar. IGK
- Cu Insulated Equipment Ground Bar. ICGK

1.

8. Feed-Thru Lugs

Cannot be used in conjunction with TVSS or sub-feed breakers.

Amp Rating	Type	Connector Cu/Al range
250	Al Lay-in Mechanical	(1) #6 AWG- (1) 350 Kcmil
	Cu Lay-in Mechanical	(1) #6 AWG (1) 350 Kcmil
	Al Compression	(1) #6 AWG (1) 350 Kcmil
400	Al Mechanical	(2) 3/0 AWG (1) 600 Kcmil

9. Circuit Breaker Accessories

For detailed information please consult the SpeedFax Catalogue.

10. Main Bus

Standard main bus is tin plated aluminum. Copper main bus is optional. Includes copper neutral cross bar. For copper neutral branch lugs, see miscellaneous.

11. Shunt Trip on Main or Branch

QJ2, QJ2-H, QJH2, ED2, ED4, ED6, HED4
FD6, FXD6, HFD6, JXD6, JD6, HJD6, HHJD6

BL, BLH, HBL, BQD6, as branch only. BL, BLH, HBL uses 1" unit space for shunt trip. All others may be used on mains or sub-feeds

Space and Mounting Provisions Only

* Compression lugs not available with 200% neutral



Factory Assembled Panelboards

SELECTION

Modifications and Additions

Compression Lugs

Panel Type	Style	Amp Rating	Breaker Type	Compression Connectors	Box Height Addition	
P1	MLO	250	N/A	(1) #4W G-35Kcmil	None	
	Feed-Thru	400	N/A	(1) 250-60cmil (2) #3AW G-25Kcmil	None	
	Main Breaker		100	ED4, ED6, HED4	(1) #12-4W G	24W Box
			225	QJ2, QJH2, QJ2H	(1) #6W G-35Kcmil DuorAl	24W Box for 1 Breakers.
			250	FD6, FXD6	(1) #6W G-35Kcmil DuorAl	24W Box for 1 Breakers.

24" box available, please consult your local Siemens representative for details & additional cost.

Enclosure Modifications

NEMA-4 For Type P1

Water Tight, Dust Tight
Steel Enclosure (consult
plant for actual enclosure
size)

Box Height (in.)	Enclosure Size		
	H	W	D
32	36	24	8
38	42	30	8
44	48	36	8
56	60	36	8
62	66	36	10
68	72	36	10

NEMA-4X For Type P1

Water Tight, Dust Tight and Corrosion Resistant
(consult plant for actual enclosure size)

Box Height (in.)	Enclosure - Stainless Steel & Steel with Epoxy Coating			Enclosure - Fiberglass Size (in.)		
	H	W	D	H	W	D
32	36	24	8	36	24	8
38	48	36	8	48	36	12
44	48	36	8	48	36	12
56	60	36	12	60	36	12
62	66	36	12	66	36	12
68	72	36	12	72	36	12

Panelboards

SELECTION

P1 Dimensions and Weights - Type P1

Main Breaker Gutter Dimensions

Main Breaker	Side Gutter	Neutral Location
	20" w/box	20" w/box
BL, BLH, HBL, BQD6	8.500"	11.500"
ED2, ED4, ED6, HED4	6.125"	11.500"
QJ2, QJH2, QJ2-H	6.500"	11.500"
FD6, FXD6, HFD6	5.250"	11.500"
JD6 ¹ , JXD6 ¹	15.000"	26.750"

Side Gutter Wiring Space

Reference Letter	Panel Width 20"
A	6.375"
B	5.500"
C	6.125"
D ²	6.500"
E	5.250"

Main Lug End Gutter Dimensions

Amp Rating	End Gutter	Neutral Location
	20" w/box	20" w/box
125	10.500"	11.500"
250	10.500"	11.500"
400	25.500"	26.750"

Note: Feed-thru lug and neutral wire bending space is 15.000" and 16.250" respectively on 400A panel.

Breaker Side Gutters

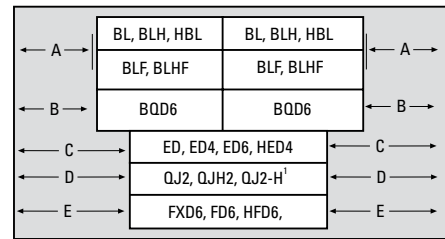

Pressure Wire Connectors

Breaker Type	Amp Rating	Line Connectors	
		Al Wire	Cu Wire
BL, BLH, HBL, BQD6	15-20	(1) #12-#8 AWG	(1) #14-#8 AWG
	25-35	(1) #8-#4 AWG	(1) #8-#6 AWG
	40-50	(1) #8-#4 AWG	(1) #8-#6 AWG
	55-70	(1) #8-#2 AWG	(1) #8-#4 AWG
QJ2, QJH2, QJ2-H	80-100	(1) #2-#1/0 AWG	(1) #4-#1/0 AWG
	60-225	(1) #4 AWG-#300 Kcmil	(1) #6 AWG-#300 Kcmil
ED2, ED4, ED6, HED4	15-20	(1) #12-#10 AWG	(1) #14-#10 AWG
	25	(1) #10 AWG	(1) #10 AWG
	30-100	(1) #10-#1/0 AWG	(1) #10-#1/0 AWG
FXD6, FD6, HFD6	110-125	(1) #2/0-1	(1) #3/0-3
	70-250	(1) #4 AWG-350 Kcmil	(1) #6 AWG-350 Kcmil
JXD6, JD6, HJD6, HHJD6	200-400	(2) 4/0-500 Kcmil	(2) 3/0-500 Kcmil

P1 Panelboard Dimensions
Approximate Weight

Max. Amps	Max. No. of Circuits	Unit Space (in.)	Box Height (in.)	Approximate Weight
100	18	9	32	105 lbs.
	30	15	38	120 lbs.
	42	21	44	135 lbs.
125	18	9	32	110 lbs.
	30	15	38	125 lbs.
	42	21	44	140 lbs.
225	18	9	32	110 lbs.
	30	15	38	125 lbs.
	42	21	44	140 lbs.
250	18	9	32	115 lbs.
	30	15	38	130 lbs.
	42	21	44	145 lbs.
400	18	9	56	135 lbs.
	30	15	62	150 lbs.
	42	21	68	165 lbs.

Standard Branch Neutral Lugs for BL and BQD6 breakers

Panel Type	No. of cct	Wire Size - Branch Neutral Lugs	Quantities
P1	18cct	#4 - 1/0 Cu or Al	9 x #4 & 9x 1/0
	30cct	#4 - 1/0 Cu or Al	16 x #4 & 16x 1/0
	42cct	#4 - 1/0 Cu or Al	23 x #4 & 23x 1/0

¹ 400A Main breaker is vertical mounted
² P1 Panel limited to (1) sub-feed 250 amperes max.

PANELBOARDS

Panelboards

SELECTION

Cross Reference

Main Amp Rating	Main Breaker		Mounting Kit	Convertible Mains	Front		Box	Main Lugs		Mounting Kit	Convertible Mains
	Old Factory Assembled No.	New Factory Assembled No.			Surface	Flush		Old Factory Assembled No.	New Factory Assembled No.		
1 Phase 3 Wire – 120/240V											
100	S1A18BL100A S1A18BL100C S1A30BL100A S1A30BL100C S1A42BL100A S1A42BL100C	P1A18BL100A P1A18BL100C P1A30BL100A P1A30BL100C P1A42BL100A P1A42BL100C	MBKBL1 MBKBL1 MBKBL1 MBKBL1 MBKBL1 MBKBL1	P1A18MC250A P1A18MC250C P1A30MC250A P1A30MC250C P1A42MC250A P1A42MC250C	S32B S32B S38B S38B S44B S44B	F32B F32B F38B F38B F44B F44B	B32 B32 B38 B38 B44 B44	– – – – – –	– – – – – –	– – – – – –	– – – – – –
125	S1A18E125A S1A18E125C S1A30E125A S1A30E125C S1A42E125A S1A42E125C	P1A18E125A P1A18E125C P1A30E125A P1A30E125C P1A42E125A P1A42E125C	MBKED1 MBKED1 MBKED1 MBKED1 MBKED1 MBKED1	P1A18MC250A P1A18MC250C P1A30MC250A P1A30MC250C P1A42MC250A P1A42MC250C	S32B S32B S38B S38B S44B S44B	F32B F32B F38B F38B F44B F44B	B32 B32 B38 B38 B44 B44	S1A18ML125A S1A18ML125C S1A30ML125A S1A30ML125C S1A42ML125A S1A42ML125C	P1A18ML125A P1A18ML125C P1A30ML125A P1A30ML125C P1A42ML125A P1A42ML125C	MLKA1 MLKA1 MLKA1 MLKA1 MLKA1 MLKA1	P1A18MC125A P1A18MC125C P1A30MC125A P1A30MC125C P1A42MC125A P1A42MC125C
225	S1A18QJ225A S1A18QJ225C S1A30QJ225A S1A30QJ225C S1A42QJ225A S1A42QJ225C	P1A18QJ225A P1A18QJ225C P1A30QJ225A P1A30QJ225C P1A42QJ225A P1A42QJ225C	MBKQJ1 MBKQJ1 MBKQJ1 MBKQJ1 MBKQJ1 MBKQJ1	P1A18MC250A P1A18MC250C P1A30MC250A P1A30MC250C P1A42MC250A P1A42MC250C	S32B S32B S38B S38B S44B S44B	F32B F32B F38B F38B F44B F44B	B32 B32 B38 B38 B44 B44	– – – – – –	– – – – – –	– – – – – –	– – – – – –
250	S1A18FX250A S1A18FX250C S1A30FX250A S1A30FX250C S1A42FX250A S1A42FX250C	P1A18FX250A P1A18FX250C P1A30FX250A P1A30FX250C P1A42FX250A P1A42FX250C	MBKFD1 MBKFD1 MBKFD1 MBKFD1 MBKFD1 MBKFD1	P1A18MC250A P1A18MC250C P1A30MC250A P1A30MC250C P1A42MC250A P1A42MC250C	S32B S32B S38B S38B S44B S44B	F32B F32B F38B F38B F44B F44B	B32 B32 B38 B38 B44 B44	S1A18ML250A S1A18ML250C S1A30ML250A S1A30ML250C S1A42ML250A S1A42ML250C	P1A18ML250A P1A18ML250C P1A30ML250A P1A30ML250C P1A42ML250A P1A42ML250C	MLKA1 MLKA1 MLKA1 MLKA1 MLKA1 MLKA1	P1A18MC250A P1A18MC250C P1A30MC250A P1A30MC250C P1A42MC250A P1A42MC250C
400	– – – – S1A42JD400A S1A42JD400C	P1A18JD400A P1A18JD400C P1A30JD400A P1A30JD400C P1A42JD400A P1A42JD400C	MBKJD1 MBKJD1 MBKJD1 MBKJD1 MBKJD1 MBKJD1	P1A18MC400A P1A18MC400C P1A30MC400A P1A30MC400C P1A42MC400A P1A42MC400C	S56B S56B S62B S62B S68B S68B	F56B F56B F62B F62B F68B F68B	B56 B56 B62 B62 B68 B68	– – – – S1A42ML400A S1A42ML400C	P1A18ML400A P1A18ML400C P1A30ML400A P1A30ML400C P1A42ML400A P1A42ML400C	4MLKA1 4MLKA1 4MLKA1 4MLKA1 4MLKA1 4MLKA1	P1A18MC400A P1A18MC400C P1A30MC400A P1A30MC400C P1A42MC400A P1A42MC400C
3 Phase 4 Wire – 208Y/120V											
100	S1C18BL100A S1C18BL100C S1C30BL100A S1C30BL100C S1C42BL100A S1C42BL100C	P1C18BL100A P1C18BL100C P1C30BL100A P1C30BL100C P1C42BL100A P1C42BL100C	MBKBL3 MBKBL3 MBKBL3 MBKBL3 MBKBL3 MBKBL3	P1C18MC250A P1C18MC250C P1C30MC250A P1C30MC250C P1C42MC250A P1C42MC250C	S32B S32B S38B S38B S44B S44B	F32B F32B F38B F38B F44B F44B	B32 B32 B38 B38 B44 B44	– – – – – –	– – – – – –	– – – – – –	– – – – – –
125	S1C18E125A S1C18E125C S1C30E125A S1C30E125C S1C42E125A S1C42E125C	P1C18E125A P1C18E125C P1C30E125A P1C30E125C P1C42E125A P1C42E125C	MBKED3 MBKED3 MBKED3 MBKED3 MBKED3 MBKED3	P1C18MC250A P1C18MC250C P1C30MC250A P1C30MC250C P1C42MC250A P1C42MC250C	S32B S32B S38B S38B S44B S44B	F32B F32B F38B F38B F44B F44B	B32 B32 B38 B38 B44 B44	S1C18ML125A S1C18ML125C S1C30ML125A S1C30ML125C S1C42ML125A S1C42ML125C	P1C18ML125A P1C18ML125C P1C30ML125A P1C30ML125C P1C42ML125A P1C42ML125C	MLKA3 MLKA3 MLKA3 MLKA3 MLKA3 MLKA3	P1C18MC125A P1C18MC125C P1C30MC125A P1C30MC125C P1C42MC125A P1C42MC125C
225	S1C18QJ225A S1C18QJ225C S1C30QJ225A S1C30QJ225C S1C42QJ225A S1C42QJ225C	P1C18QJ225A P1C18QJ225C P1C30QJ225A P1C30QJ225C P1C42QJ225A P1C42QJ225C	MBKQJ3 MBKQJ3 MBKQJ3 MBKQJ3 MBKQJ3 MBKQJ3	P1C18MC250A P1C18MC250C P1C30MC250A P1C30MC250C P1C42MC250A P1C42MC250C	S32B S32B S38B S38B S44B S44B	F32B F32B F38B F38B F44B F44B	B32 B32 B38 B38 B44 B44	– – – – – –	– – – – – –	– – – – – –	– – – – – –
250	S1C18FX250A S1C18FX250C S1C30FX250A S1C30FX250C S1C42FX250A S1C42FX250C	P1C18FX250A P1C18FX250C P1C30FX250A P1C30FX250C P1C42FX250A P1C42FX250C	MBKFD3 MBKFD3 MBKFD3 MBKFD3 MBKFD3 MBKFD3	P1C18MC250A P1C18MC250C P1C30MC250A P1C30MC250C P1C42MC250A P1C42MC250C	S32B S32B S38B S38B S44B S44B	F32B F32B F38B F38B F44B F44B	B32 B32 B38 B38 B44 B44	S1C18ML250A S1C18ML250C S1C30ML250A S1C30ML250C S1C42ML250A S1C42ML250C	P1C18ML250A P1C18ML250C P1C30ML250A P1C30ML250C P1C42ML250A P1C42ML250C	MLKA3 MLKA3 MLKA3 MLKA3 MLKA3 MLKA3	P1C18MC250A P1C18MC250C P1C30MC250A P1C30MC250C P1C42MC250A P1C42MC250C
400	– – – – S1C42JD400A S1C42JD400C	P1C18JD400A P1C18JD400C P1C30JD400A P1C30JD400C P1C42JD400A P1C42JD400C	MBKJD3 MBKJD3 MBKJD3 MBKJD3 MBKJD3 MBKJD3	P1C18MC400A P1C18MC400C P1C30MC400A P1C30MC400C P1C42MC400A P1C42MC400C	S56B S56B S62B S62B S68B S68B	F56B F56B F62B F62B F68B F68B	B56 B56 B62 B62 B68 B68	– – – – S1C42ML400A S1C42ML400C	P1C18ML400A P1C18ML400C P1C30ML400A P1C30ML400C P1C42ML400A P1C42ML400C	4MLKA3 4MLKA3 4MLKA3 4MLKA3 4MLKA3 4MLKA3	P1C18MC400A P1C18MC400C P1C30MC400A P1C30MC400C P1C42MC400A P1C42MC400C
3 Phase 4 Wire – 600Y/347V											
100	S2L18BD100A S2L18BD100C S2L30BD100A S2L30BD100C S2L42BD100A S2L42BD100C	P1L18BD100A P1L18BD100C P1L30BD100A P1L30BD100C P1L42BD100A P1L42BD100C	MBKBC3 MBKBC3 MBKBC3 MBKBC3 MBKBC3 MBKBC3	P1L18MC250A P1L18MC250C P1L30MC250A P1L30MC250C P1L42MC250A P1L42MC250C	S32B S32B S38B S38B S44B S44B	F32B F32B F38B F38B F44B F44B	B32 B32 B38 B38 B44 B44	– – – – – –	– – – – – –	– – – – – –	– – – – – –
125	S2L18E6125A S2L18E6125C S2L30E6125A S2L30E6125C S2L42E6125A S2L42E6125C	P1L18E6125A P1L18E6125C P1L30E6125A P1L30E6125C P1L42E6125A P1L42E6125C	MBKED3 MBKED3 MBKED3 MBKED3 MBKED3 MBKED3	P1L18MC250A P1L18MC250C P1L30MC250A P1L30MC250C P1L42MC250A P1L42MC250C	S32B S32B S38B S38B S44B S44B	F32B F32B F38B F38B F44B F44B	B32 B32 B38 B38 B44 B44	S2L18ML125A S2L18ML125C S2L30ML125A S2L30ML125C S2L42ML125A S2L42ML125C	P1L18ML125A P1L18ML125C P1L30ML125A P1L30ML125C P1L42ML125A P1L42ML125C	MLKA3 MLKA3 MLKA3 MLKA3 MLKA3 MLKA3	P1L18MC125A P1L18MC125C P1L30MC125A P1L30MC125C P1L42MC125A P1L42MC125C
250	S2L18FD250A S2L18FD250C S2L30FD250A S2L30FD250C S2L42FD250A S2L42FD250C	P1L18FD250A P1L18FD250C P1L30FD250A P1L30FD250C P1L42FD250A P1L42FD250C	MBKFD3 MBKFD3 MBKFD3 MBKFD3 MBKFD3 MBKFD3	P1L18MC250A P1L18MC250C P1L30MC250A P1L30MC250C P1L42MC250A P1L42MC250C	S32B S32B S38B S38B S44B S44B	F32B F32B F38B F38B F44B F44B	B32 B32 B38 B38 B44 B44	S2L18ML250A S2L18ML250C S2L30ML250A S2L30ML250C S2L42ML250A S2L42ML250C	P1L18ML250A P1L18ML250C P1L30ML250A P1L30ML250C P1L42ML250A P1L42ML250C	MLKA3 MLKA3 MLKA3 MLKA3 MLKA3 MLKA3	P1L18MC250A P1L18MC250C P1L30MC250A P1L30MC250C P1L42MC250A P1L42MC250C
400	– – – – S2L42JD400A S2L42JD400C	P1L18JD400A P1L18JD400C P1L30JD400A P1L30JD400C P1L42JD400A P1L42JD400C	MBKJD3 MBKJD3 MBKJD3 MBKJD3 MBKJD3 MBKJD3	P1L18MC400A P1L18MC400C P1L30MC400A P1L30MC400C P1L42MC400A P1L42MC400C	S56B S56B S62B S62B S68B S68B	F56B F56B F62B F62B F68B F68B	B56 B56 B62 B62 B68 B68	– – – – S2L42ML400A S2L42ML400C	P1L18ML400A P1L18ML400C P1L30ML400A P1L30ML400C P1L42ML400A P1L42ML400C	4MLKA3 4MLKA3 4MLKA3 4MLKA3 4MLKA3 4MLKA3	P1L18MC400A P1L18MC400C P1L30MC400A P1L30MC400C P1L42MC400A P1L42MC400C

PANELBOARDS

Flexibility is the hallmark of the P2 panel. This panel offers a wide array of factory-assembled options to meet almost all lighting panel applications. With this design, the ability to mix breaker frames in unit space up to 250 amps will also meet many distribution panel requirements in a much smaller package. Busing options for the P2 vary from the typical temperature rated to 750 A/Si aluminum to 1000A/Si copper. Standard busing in the P2 panel is tin-plated. Silver-plated copper is also offered as an option. Integrated time clocks, bus mounted contactors, as mains or sub mains, split bus, and subfeed lugs (up to 400 amp) are just a few of the options of this unique panel.

Like a lighting panel, P2 is set up around 18, 30, 42, and 54 circuit configurations. It will also allow the user to configure the panel to the smallest possible size. The P2 panel starts with 9" of unit space (18 circuits of 1" pole breakers). Breakers mounted in unit space can be mixed and matched to meet customer requirements. All 1" pole breakers (BL, BQD6, ED frames) are mounted in 3" or 6" pole increments. Breaker frames, above 125 amps, are mounted in 6" single breaker mountings. As an example of a minimum panel, (6) 20 amp 1-pole BL breakers (3" of unit space) and a 3-pole 225 amp QJ breaker (6" of unit space) equaling 9" of unit space can be configured in a P2 panel without any extra provisions or space required. FD 250 amp and JD 400 amp breakers are mounted as subfeed breakers outside of unit space.

Another unique feature of the P2 panel is that blank unit space can be added to allow for future expansions or modifications. Any expansions or modifications must be in 3" increments. BL, BQD, and ED frame breakers have 3" or 6" pole kits, and can be mixed in unit space by these increments. Breakers of the same frame can cross from one mounting to another if contiguous. QJ frame breakers are mounted in 6" increments for two and three pole, single mounted units. Changes in the unit space length for BL, BQD, or ED frame breakers require an addition deadfront, center strip kit. Check with sales or the factory for additional unit space kits.

Main Lug / Main Breaker

Enclosure – Standard Type 1 enclosure is 20" wide x 5.75" deep X. Box Height is determined by main device and unit space. See charts for box height.

Voltage – 600 Vac Max.
250 Vdc Max.

Amperage – 600 amp Max.

Short circuit rating – 200 KAIC Max. symmetrical or equal to the lowest rated device installed unless a series rating is indicated. Panels with subfeed or feed-thru lugs without a main device, circuit breaker or fusible unit, are limited to a three-cycle rating. The three-cycle rating for the P2 panel is limited to 22 KAIC. Note that the main device may be mounted remote from the panel.

Busing – The P2 panel has more options to meet market requirements. The standard busing is temperature rated aluminum. The rating is per the requirements of CSA: 22.2 No. 29 – the standard for panelboards. All aluminum busing is tin-plated. Optional busing for the P2 panel is: 750 A/Si aluminum, temperature rated copper, and 1000 A/Si copper. The copper bus option for this panel is tin-plated.

Weight – Approximate

Total panelboard weight when filled with a normal quantity of breakers and accessories is about 3 lbs. (1 kg) per inch (54g per mm) of box height.

Table P2-1 – Gauge Steel of Boxes Fronts, Surface and Flush

Dimensions in inches (mm)		Gauge Steel	
Width	Height	Box	Front
20" (508)	26 - 74 (660, 1880)	#16	#14

Selection and Application

Step 1

Determine configuration required.

Example:

- Amperage 250A
- Voltage 208Y/120V
- System 3Ø4W
- Main Main Lug
- Bus Material Temperature rated aluminum
- Interrupt Rating 10 Ka
- Branch Devices (6) 20 amp, 1-pole
(1) 225 amp, 3-pole
- Feed Location Top
- Mounting Surface

Step 2

Create a catalogue number by following the Catalogue Numbering System on page 7-5

6. Note that the number of circuits number (4th and 5th position) will be 18 for those panels with 6-18 circuits, 30 for those panels with 19-30 circuits, 42 for those panels 31 to 42 circuits and 54 for those panels 43 to 54 circuits. The most cost effective 20 amp 1-pole breaker for this application would be BL. However, a myriad of other breakers with options may be used in the P2 panel. The most cost effective 225 amp breaker for this application is the QJ2.

Based on the above
P2C18ML250ATS
(6) BL 20 amp 1-Pole
(1) QJ2 225 amp 3-pole

Step 3

Determine the enclosure size. The matrix on page 2-3 shows the enclosure sizes based on the amperage, main device and unit space required.



Table P2-2 – Panel Unit Space To Box Height Requirements

"B" Dimension Box Height	P2 Panels With Standard Line Lugs. Unit Space (starting with 9" and adding 6" increments) "A" Dimension													
	Main Lugs				Main Breakers									
	125A	250A	400A	600A	125A Horiz. BL,BQD6,ED	125A Horiz. CED	125A Vert. ED	225A Horiz. QJ	250A Horiz. FD	250A Vert. CFD	400A JD	400A CJD	600A LD	600A CLD
26	9	—	—	—	9	—	—	—	—	—	—	—	—	—
32	15	9	—	—	15	9	9	9	—	—	—	—	—	—
38	21	15	9	9	21	15	15	15	9	—	—	—	—	—
44	27	21	15	15	27	21	21	21	15	—	—	—	—	—
50	33	27	21	21	33	27	27	27	21	9	9	—	—	—
56	39	33	27	27	39	33	33	33	27	15	15	—	9	—
62	45	39	33	33	45	39	39	39	33	21	21	9	15	9
68*	51*	45	39	39	51*	45	45	45	39	27	27	15	21	15
74*	57*	51*	45	45	57*	51*	51*	51*	45	33	33	21	27	21

Table P2-3 – Main Breaker (Fig. P2-1)

Panel Amps	Breaker Frames	C	D
100	BL	5.75	8.00
	BQD	5.125	8.00
125	ED	4.00	8.00
225	QJ	5.00	7.00
250	FD	5.00	7.00
400	JD	14.00	25.00
600	LD	15.50	23.00

Table P2-4 – Main Lug Connectors (Fig. P2-2)

Panel Amps	Standard Connectors	C	D
125	(1) #14 - 270	6.62	8.19
250	(1) #6 AWG - 350 Kcmil	12.34	11.22
400	(1) #4 AWG - 600 Kcmil	14.00	13.09
600	or (2) #6 - 250 Kcmil (2) #4 AWG - 500 Kcmil	14.00	11.00

Fig. P2-1

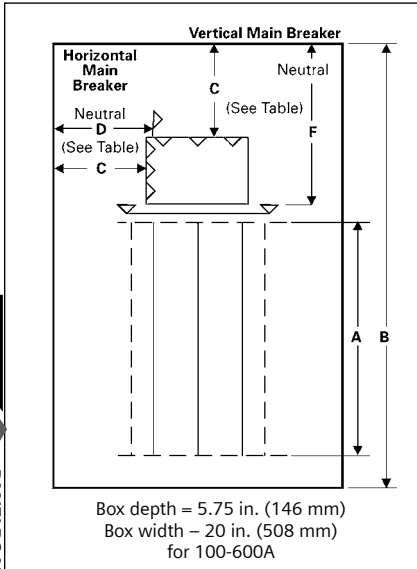

Fig. P2-2

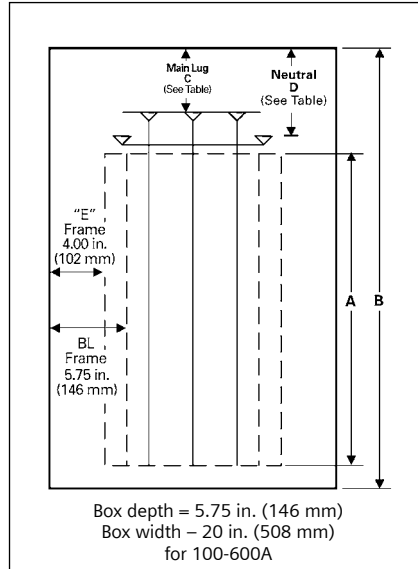
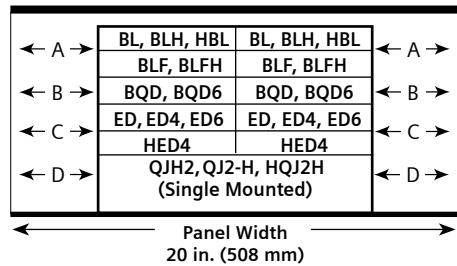

Table P2-5 – Branch Breaker Side Gutters Inches (mm) (Fig. P2-3)

Reference Letter	Panel Width 20" (508)
A	5.750 (146)
B	5.125 (130)
C	4.000 (102)
D ①	5.000 (127)

① Single branch mounting construction.

Fig. P2-3



PANELBOARDS

*Contact local Siemens representative before ordering.

Table P2-6 – Main Breaker Selection ①

Ampere Rating	Breaker Type	Maximum Interrupting Rating (kA)			Available Trip Values
		240V	480V	600V	
100	BL	10	—	—	15, 20, 25, 30, 35, 40, 50, 60, 70, 80, 90, 100
	HBL	65	—	—	
	BQD6	65	10	10	
	ED4	65	25	—	
	ED6	100	42	18	
	HED4	100	65	—	
	CED6	200	200	100	
125	ED4	65	18	—	— 125
	ED6	65	25	18	
	HED4	100	—	42	
	CED6	200	200	100	
225	QJ2	10	—	—	60, 70, 80, 90, 100, 110, 125, 150, 175, 200, 225
	QJH2	22	—	—	
	QJ2H	42	—	—	
	FD6, FXD6	65	35	18	70, 80, 90, 100, 110, 125, 150, 175, 200, 225
	HFD6, HFXD6	100	65	25	
	CFD6	200	150	100	
	FD6, FXD6	65	35	18	
250	HFD6, HFXD6	100	65	25	250
	CFD6	200	150	100	
	FD6, FXD6	65	35	18	
400	JXD6, JD6	65	35	25	200, 225, 250, 300, 350, 400
	HJD6, HJXD6	100	65	35	200, 225, 250, 300, 350, 400
	SJD6	65	35	25	200, 300, 400
	CJD6, SCJD6	200	200	100	200, 300, 400
600	LXD6	65	35	25	450, 500, 600
	LD6	65	35	25	250, 300, 350, 400, 450, 500, 600
	HLD6, HLXD6	100	65	35	250, 300, 350, 400, 450, 500, 600
	SLD6,	65	35	25	300, 400, 500, 600
	SHLD6	100	65	35	300, 400, 500, 600
	CLD6, SCLD6	200	150	100	300, 400, 500, 600

① Interchangeable trip main breakers are mounted at top of panel only.

Table P2-7 – Subfeed Breakers

Breaker Type	Mounting Position When Used As Subfeed Breaker	Maximum Interrupting Rating (kA) Symmetrical	240V AC	480V AC	600V DC
	Vertical	Ampere Ratings For Load			
FD6 ①, FXD6	Twin	70 - 250	65	35	18
HFD6 ①, HFXD6	Twin	70 - 250	100	65	25
JD6 ②, JXD6	Single	200 - 400	65	35	25
HJD6 ②, HJXD6	Single	200 - 400	100	65	35

① Twin mounted subfeed breakers are mounted at bottom of panelboard only and adds 24" to the panel height.

② Subfeed breaker is mounted at bottom of panelboard only. 400 amp subfeed breaker adds 30" to the panel height.

Table P2-9A - Standard Branch Neutral Lugs for BL BQD6 and ED breakers

Panel Type	No. of cct	Wire Size - Branch Neutral Lugs	Quantities
P2	18cct	#6 - 1/0 Cu or Al	18 x #6 & 3x 1/0
	30cct	#6 only Cu or Al	16 x #6 (qty 2)
	42cct	#6 - 1/0 Cu or Al	18 x #6 & 3x 1/0 (qty 2)
	54cct	#6 - 1/0 Cu or Al	12 x #6 & 14 x 1/0 (qty 2)
	66cct	#6 - 1/0 Cu or Al	12 x #6 & 14 x 1/0
		#4 - #14 & #14-3/0 Cu or Al	36 x #4-14 & 6 X #14-3/0
	78cct	#4 - #14 & #14-3/0 Cu or Al	36 x #4-14 & 6 X #14-3/0 (qty 2)
	90cct	#4 - #14 & #14-3/0 Cu or Al	36 x #4-14 & 6 X #14-3/0 (qty 2)
102cct	#4 - #14 & #14-3/0 Cu or Al	36 x #4-14 & 6 X #14-3/0 (qty 2)	

Table P2-8 – Branch Circuit Breakers

Max. Amp Rating	Bolt-On Breaker Type	No. of Poles	Amp Rating	Maximum Interrupting Rating (kA)						
				Volts – AC						DC
				120	120/240	240	277	480	600	250
100	BL	1	15 - 70	10	—	—	—	—	—	—
		2	15 - 100	—	10	—	—	—	—	—
		3	15 - 100	—	—	10	—	—	—	—
	BL, HID	1	15 - 30	10	—	—	—	—	—	—
		2	15 - 30	—	10	—	—	—	—	—
	BLE	2	15 - 100	—	—	10	—	—	—	—
		1	15 - 30	10	—	—	—	—	—	—
	BLEH	2	15 - 60	—	10	—	—	—	—	—
		1	15 - 30	22	—	—	—	—	—	—
	BLF	2	15 - 60	—	22	—	—	—	—	—
		1	15 - 30	10	—	—	—	—	—	—
	BLHF	2	15 - 60	—	10	—	—	—	—	—
		3	15 - 60	—	10	—	—	—	—	—
		1	15 - 30	22	—	—	—	—	—	—
	BAF	3	15 - 30	10	—	—	—	—	—	—
		3	15 - 30	—	10	—	—	—	—	—
	BAFH	1	15, 20	10	—	—	—	—	—	—
		1	15, 20	22	—	—	—	—	—	—
BLH	1	15 - 70	—	22	—	—	—	—	—	
	2	15 - 100	—	22	—	—	—	—	—	
	3	15 - 100	—	—	22	—	—	—	—	
HBL	1	15 - 70	—	65	—	—	—	—	—	
	2	15 - 100	—	65	—	—	—	—	—	
	3	15 - 100	—	—	65	—	—	—	—	
BQD6	1	—	—	65	—	14	—	—	14	
	2	15 - 100	—	65	—	—	10	10	14	
	3	—	—	—	65	—	10	10	14	
125	ED2	1	15 - 100	10	—	—	—	—	—	
		2/3	—	10	—	—	—	—	5 (2-P)	
	ED4	1	15 - 125	65	—	—	22	—	—	
		2	—	—	—	65	—	18	—	
		3	—	—	—	65	—	18	—	
	ED6	2	15 - 125	—	—	65	—	25	18	
		3	—	—	—	65	—	25	18	
*CED6	1	—	—	—	—	—	—	—		
	2	15 - 125	—	200	200	200	200	100		
	3	—	—	200	200	200	200	100		
225	QJ2	2/3	60 - 225	—	—	10	—	—		
		2/3	60 - 225	—	—	22	—	—		
	HJ2H	2/3	60 - 225	—	—	42	—	—		
		2/3	100 - 225	—	—	100	—	—		

NOTE: QJ Breakers are single mounted in unit space and take 6" of unit space. Limited to (3) per panel max. BL, HBL, BLH and BQD6 breakers are mounted in

common mountings in 3" or (6) pole increments. ED2, ED4, ED6 and HED4 breakers are mounted in common mountings in 3" or (6) pole increments.

Table P2-9 – Branch Neutral Connections

Wire Range	Max. Number of Connections	Max. Amps Ⓞ
#14-#6	26	65
#14-1/0	28	125
#6 - 350 Kcmil	3	250
(1) #4-600 Kcmil or (2) #6-250 Kcmil	1	400

*Contact local Siemens representative before ordering.

ⓄBased on 75 degree copper.

Typical Catalog Numbers

SELECTION

Table P2-10 – Main Lugs Only (1)(2)(4)(5)

Maximum Panel Amp Rating	Maximum 1-Pole Circuits (6)	Box Height inches (mm)	Catalogue Number (2)			
			3Ø4W 208Y/120V	1Ø3W 120/240V	3Ø4W 480Y/27V	3Ø4W 347/600V
125	18	26	P2C18ML125ATS	P2A18ML125ATS	P2E18ML125ATS	P2L18ML125ATS
	30	32	P2C30ML125ATS	P2A30ML125ATS	P2E30ML125ATS	P2L30ML125ATS
	42	38	P2C42ML125ATS	P2A42ML125ATS	P2E42ML125ATS	P2L42ML125ATS
	54	44	P2C54ML125ATS	P2A54ML125ATS	P2E54ML125ATS	P2L54ML125ATS
	66	50	P2C66ML125ATS	P2A66ML125ATS	P2E66ML125ATS	P2L66ML125ATS
	78	56	P2C78ML125ATS	P2A78ML125ATS	P2E78ML125ATS	P2L78ML125ATS
	90	62	P2C90ML125ATS	P2A90ML125ATS	P2E90ML125ATS	P2L90ML125ATS
250	18	32	P2C18ML250ATS	P2A18ML250ATS	P2E18ML250ATS	P2L18ML250ATS
	30	38	P2C30ML250ATS	P2A30ML250ATS	P2E30ML250ATS	P2L30ML250ATS
	42	44	P2C42ML250ATS	P2A42ML250ATS	P2E42ML250ATS	P2L42ML250ATS
	54	50	P2C54ML250ATS	P2A54ML250ATS	P2E54ML250ATS	P2L54ML250ATS
	66	56	P2C66ML250ATS	P2A66ML250ATS	P2E66ML250ATS	P2L66ML250ATS
	78	62	P2C78ML250ATS	P2A78ML250ATS	P2E78ML250ATS	P2L78ML250ATS
	90	68	P2C90ML250ATS	P2A90ML250ATS	P2E90ML250ATS	P2L90ML250ATS
400	18	38	P2C18ML400ATS	P2A18ML400ATS	P2E18ML400ATS	P2L18ML400ATS
	30	44	P2C32ML400ATS	P2A32ML400ATS	P2E32ML400ATS	P2L32ML400ATS
	42	50	P2C42ML400ATS	P2A42ML400ATS	P2E42ML400ATS	P2L42ML400ATS
	54	56	P2C54ML400ATS	P2A54ML400ATS	P2E54ML400ATS	P2L54ML400ATS
	66	62	P2C66ML400ATS	P2A66ML400ATS	P2E66ML400ATS	P2L66ML400ATS
	78	68	P2C78ML400ATS	P2A78ML400ATS	P2E78ML400ATS	P2L78ML400ATS
	90	74	P2C90ML400ATS	P2A90ML400ATS	P2E90ML400ATS	P2L90ML400ATS
600	18	38	P2C18ML600ATS	P2A18ML600ATS	P2E18ML600ATS	P2L18ML600ATS
	30	44	P2C30ML600ATS	P2A30ML600ATS	P2E30ML600ATS	P2L30ML600ATS
	42	50	P2C42ML600ATS	P2A42ML600ATS	P2E42ML600ATS	P2L42ML600ATS
	54	56	P2C54ML600ATS	P2A54ML600ATS	P2E54ML600ATS	P2L54ML600ATS
	66	62	P2C66ML600ATS	P2A66ML600ATS	P2E66ML600ATS	P2L66ML600ATS
	78	68	P2C78ML600ATS	P2A78ML600ATS	P2E78ML600ATS	P2L78ML600ATS
	90	74	P2C90ML600ATS	P2A90ML600ATS	P2E90ML600ATS	P2L90ML600ATS

Table P2-11 - Main Circuit Breaker (1)(2)(3)(4)(5)

Maximum Panel Amp Rating	Maximum 1-Pole Circuits	Box Height inches (mm)	Catalogue Number (2)			
			3Ø4W 120/208V	1Ø3W 120/240V	3Ø4W 277/480V	3Ø4W 347/600V
100	18	26	P2C18BL100ATS	P2A18BL100ATS	P2E18BD100ATS	P2L18BD100ATS
	30	32	P2C30BL100ATS	P2A30BL100ATS	P2E30BD100ATS	P2L30BD100ATS
	42	38	P2C42BL100ATS	P2A42BL100ATS	P2E42BD100ATS	P2L42BD100ATS
	54	44	P2C54BL100ATS	P2A54BL100ATS	P2E54BD100ATS	P2L54BD100ATS
	66	50	P2C66BL100ATS	P2A66BL100ATS	P2E66BD100ATS	P2L66BD100ATS
	78	56	P2C78BL100ATS	P2A78BL100ATS	P2E78BD100ATS	P2L78BD100ATS
	90	62	P2C90BL100ATS	P2A90BL100ATS	P2E90BD100ATS	P2L90BD100ATS
125	18	26	P2C18E4125ATS	P2A18E4125ATS	P2E18E4125ATS	P2L18E6125ATS
	30	32	P2C30E4125ATS	P2A30E4125ATS	P2E30E4125ATS	P2L30E6125ATS
	42	38	P2C42E4125ATS	P2A42E4125ATS	P2E42E4125ATS	P2L42E6125ATS
	54	44	P2C54E4125ATS	P2A54E4125ATS	P2E54E4125ATS	P2L54E6125ATS
	66	50	P2C66E4125ATS	P2A66E4125ATS	P2E66E4125ATS	P2L66E6125ATS
	78	56	P2C78E4125ATS	P2A78E4125ATS	P2E78E4125ATS	P2L78E6125ATS
	90	62	P2C90E4125ATS	P2A90E4125ATS	P2E90E4125ATS	P2L90E6125ATS
225	18	32	P2C18QJ225ATS	P2A18QJ225ATS	P2E18E4225ATS	P2L18E6225ATS
	30	38	P2C32QJ225ATS	P2A32QJ225ATS	P2E32E4225ATS	P2L32E6225ATS
	42	44	P2C42QJ225ATS	P2A42QJ225ATS	P2E42E4225ATS	P2L42E6225ATS
	54	50	P2C54QJ225ATS	P2A54QJ225ATS	P2E54E4225ATS	P2L54E6225ATS
	66	56	P2C66QJ225ATS	P2A66QJ225ATS	P2E66E4225ATS	P2L66E6225ATS
	78	62	P2C78QJ225ATS	P2A78QJ225ATS	P2E78E4225ATS	P2L78E6225ATS
	90	68	P2C90QJ225ATS	P2A90QJ225ATS	P2E90E4225ATS	P2L90E6225ATS
250	18	38	P2C18FX250ATS	P2A18FX250ATS	P2E18FX250ATS	P2L18FX250ATS
	30	44	P2C30FX250ATS	P2A30FX250ATS	P2E30FX250ATS	P2L30FX250ATS
	42	50	P2C42FX250ATS	P2A42FX250ATS	P2E42FX250ATS	P2L42FX250ATS
	54	56	P2C54FX250ATS	P2A54FX250ATS	P2E54FX250ATS	P2L54FX250ATS
	66	62	P2C66FX250ATS	P2A66FX250ATS	P2E66FX250ATS	P2L66FX250ATS
	78	68	P2C78FX250ATS	P2A78FX250ATS	P2E78FX250ATS	P2L78FX250ATS
	90	74	P2C90FX250ATS	P2A90FX250ATS	P2E90FX250ATS	P2L90FX250ATS
400	18	50	P2C18JX400ATS	P2A18JX400ATS	P2E18JX400ATS	P2L18JX400ATS
	30	56	P2C32JX400ATS	P2A32JX400ATS	P2E32JX400ATS	P2L32JX400ATS
	42	62	P2C42JX400ATS	P2A42JX400ATS	P2E42JX400ATS	P2L42JX400ATS
	54	66	P2C54JX400ATS	P2A54JX400ATS	P2E54JX400ATS	P2L54JX400ATS
	66	74	P2C66JX400ATS	P2A66JX400ATS	P2E66JX400ATS	P2L66JX400ATS
600	18	56	P2C18LX600ATS	P2A18LX600ATS	P2E18LX600ATS	P2L18LX600ATS
	30	62	P2C30LX600ATS	P2A30LX600ATS	P2E30LX600ATS	P2L30LX600ATS
	42	68	P2C42LX600ATS	P2A42LX600ATS	P2E42LX600ATS	P2L42LX600ATS
	54	74	P2C54LX600ATS	P2A54LX600ATS	P2E54LX600ATS	P2L54LX600ATS

(1) Refer to Pg 12, table P2-21 for breaker kits and accessories--(2) Part # for Interior only--(3) Refer to Pg 4 for Main breaker selection (4) Refer to Pg 5 for Branch circuit breaker selection (5) Refer to Pg 12, table P2-20 for box and trim details--(6) For more number of circuits, contact local Siemens representative before ordering



P2 Panel Options

Enclosures

- Extra gutter to sides or ends of the can
- 24" wide boxes
- Hinged trims*
- Door-in-door trims*
- Screw to the box trims*
- Trim mounted devices (Devices mounted and wired to the trim should also have hinged trim specified)
 - Pilot lights
 - Toggle switches
 - Push buttons
- Painted boxes
- Custom colors
- Increase gauge trims and boxes*
- Stainless steel trims and boxes, Type 1*

Panel Modifications

- Main Bus
Standard main bus is temperature rated tin-plated aluminum. Bus options are 750 A/Si aluminum, tin-plated temperature rated copper tin-plated standard – silver optional. 1000 A/Si copper tin-plated standard – silver optional. Includes copper neutral cross bar. For copper neutral branch lugs, see miscellaneous.
- Split bus adds 6" to unit space*
- Compression lug for MLO*
- Compression lugs on main breaker (may require extra width or length on enclosure)*
- Contactor mains or submain*
 - Asco 920 through 225 amps. Adds 12" unit space as main, 15" unit space as submain.*
 - Siemens LEN through 30 amps. Adds 12" unit space.* Makes box 10" deep.
- Control power transformers (contact engineering for extra* gutter requirements)
- Branch and main breaker accessories
 - Handle blocks
 - Handle locks
 - Aux. Contacts ①
 - UVR ①
- Feed-thru lugs
- 200% neutral
- Copper lugs, mechanical
- Bus mounted TVSS
- Service entrance labeled

① Accessories on 1" pole breakers (BL, BQD, ED) will take unit space.

*Contact local Siemens representative for any options & modifications.

- Grounding of panelboards

- Aluminum trims and boxes, Type 1*
- NEMA 3R/12 enclosures
- NEMA 4 enclosures
- NEMA 4X enclosures
- Special keyed locks*
- Gasketing trim to box
- Panel skirts

Ground bars are shipped with the panel interior factory mounted.

- Non-insulated equipment ground bar – standard
- Copper non-insulated ground bar
- Aluminum insulated equipment ground bar
- Copper insulated equipment ground bar
- Shunt trip on main or branch
BL, BLH, HBL, ED2, ED4, HED4, HED6, HHED6 uses 1" unit space for shunt trip. All may be used on mains or subfeeds.

QJ2, QJ2-H, QJH2, HQJ2H, ED2, ED4, ED6, HED4, HED6, FXD6, HFD6, JXD6, JD6, HJD6, HJXD6

- Remote control switches – mounted in a 23" enclosure to be cable connected to the panel.
- Time clocks – mounted in a 23" enclosure to be cable connected to the panel. Sangamo, tork or paragon time clock can be supplied and mounted in panelboard cabinet.

Table P2-12 – Box Size Additions (In.) For Optional Features

Options	Main Lugs				Main Breakers									
	125A	250A	400A	600A	125A Horiz. BL, BQD, ED	125A Horiz. CED	125A Vert. ED	225A Vert. QJ	250A Vert. FD	250A Vert. CFD	400A JD	400A CJD	600A LD	600A CLD
200 Neutral (lug type)	0	0	6 (all)	6 (all)	0	0	0	6	6	0	0	0	0	0
Std. Lugs (100% Neut. PNL)	0	0	0	0	0	0	0	6	6	0	0	0	0	0
CU Lugs (100% Neut. PNL)	6	6	6	0	6	6	0	6	6	0	0	0	0	0
Comp Lugs (100% Neut. PNL)	6	6	6	6	6	6	0	6	6	0	0	0	0	0
Feed-thru Standard Lugs	6	6	12	12	6	6	6	6	6	6	12	12	12	12
Feed-thru Cu Lugs	6	6	12	N/A	6	6	6	6	6	6	12	12	12	N/A
Feed-thru Comp Lugs	6	12	12	N/A	6	6	6	6	12	12	12	12	12	N/A
Subfeed Standard Lugs	0	6	6	N/A	—	—	—	—	—	—	—	—	—	—
Split Bus	6	6	6	6	6	6	6	6	6	6	6	6	6	6
(1) FD Subfeed (Horizontal Mtg.)	N/A	12	12	12	N/A	N/A	N/A	N/A	12	12	12	12	12	12
(2) FD Subfeed (Vertical Mtg.)	N/A	24	24	24	N/A	N/A	N/A	N/A	24	24	24	24	24	24
TVSS	12	12	12	12	12	12	12	12	12	12	12	12	12	12

Split bus is paired with feed-thru lugs by default. Feed-thru lugs are to feed the section after the split. NOTE: N/A = OPTION NOT AVAILABLE

*Contact local Siemens representative before any modification.

Connector Modifications

SELECTION

Compression Lugs

Table P2-13 – Lugs

Style	Amp Rating	Breaker Type	Compression Connectors	Box Height Addition
MLO	125	N/A	(1)#6 - 350 Kcmil Al/Cu	6
	250	N/A	(1)#6 - 350 Kcmil Al/Cu	6
	400	N/A	(1) 400 - 600 Kcmil Cu or (2)#6 - 350 Kcmil Al/Cu	6
	600	N/A	(2)#6 - 350 Kcmil Cu or Cu/Al or 400 - 600 Kcmil Al/Cu	6
Main Breaker	100	ED4, ED6, HED4 CED6	(1)#14-2/0 AWG Cu or Al	Box must go to 24" wide on CED6 breaker only Add 6" to box height for NØ
	225	QJ2, QJH2, QJ2H FXD6, HFD6, CFD6	(1)#6 AWG - 350 Kcmil Cu or Al (1)#6 AWG - 350 Kcmil Cu or Al	Box must go to 24" wide Box must go to 24" wide for all breakers Requires an additional 6.0" box height
	400	JD6, JXD6, HJD6, CJD6, SJD6, SHJD6, SCJD6	(2)#1/0 AWG - 500 Kcmil Cu or Al	9
	600	LD6, LXD6, HLD6, CJD6, SLD6, SHLD6, SCLD6	(2)#2/0 AWG - 500 Kcmil Cu or Al	6

Table P2-14 – Alternate Lugs*

Style	Amp Rating	Breaker Type	Compression Connectors	Box Height Addition
MLO	400	N/A	(1) 250 - 750 Kcmil or (2)#3/0 AWG - 250 Kcmil Cu or Al	6
Main Breaker	400	JD6, JXD6, HJD6, CJD6, SJD6, SHJD6, SCJD6	(1)#4/0 AWG - 750 Kcmil Cu or Al	6

*Contact local Siemens representative for any modifications.

Connector Modifications

SELECTION

Enclosure Modifications

NEMA-4 For Type P2*
Water Tight, Dust Tight, Steel Enclosure

Table P2-15

Box Height Inches	Enclosure Size		
	H	W	D
26	30	24	8
32	36	24	8
38	42	30	8
44	48	36	8
50	60	36	8
56	60	36	8
62	66	36	8
68	72	36	8
74	78	36	8
80	84	36	8

NEMA-4X For Type P2*
Water Tight, Dust Tight and Corrosion Resistant

Table P2-16

Box Height Inches	Enclosure - Stainless Steel and Steel with Epoxy Coating			Enclosure - Fiberglass Size (inches)		
	H	W	D	H	D	W
26	30	24	8	30	24	8
32	36	24	8	36	24	8
38	48	36	8	48	36	12
44	48	36	8	48	36	12
50	60	36	12	60	36	12
56	60	36	12	60	36	12
62	66	36	8	72	36	8
68	72	36	8	72	36	8
74	78	36	8	84	36	8
80	84	36	8	84	36	8

Remote Switch Modifications

Table P2-17 – Control Power*
Transformer

Size	VA
0,1	50
2	75
3	150
4	250

Table P2-19 – Remote Control
Switch Modification*

Description
Auxiliary Contacts (Mounted Not Wired) Ea. 2-Wire Control

Table P2-18 – Application For Remote Switch*

Switch Type	Modification
920	Adds 12" to unit space
911	≤ 225A adds 21" unit space >225 ≤400 Amps add 10" to width and 8" DP minimum and 24" to height
LEN	30A adds 15" to unit space >30A 100 adds 12" to unit space 7.7 Dp. Box min. 100 A ≤ 200 adds 12" to unit space and 10" DP. min.

*Contact local Siemens representative for any modifications.

Dimensions

SELECTION

Type 1 Box

Box is symmetrical

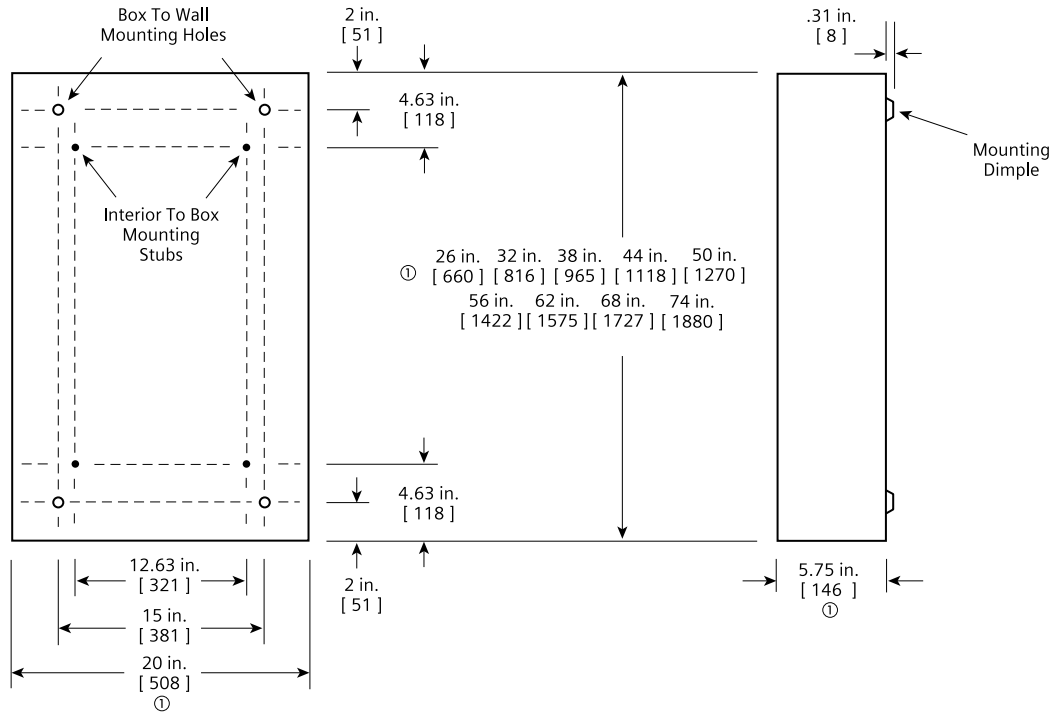

Type 3R/12 Box

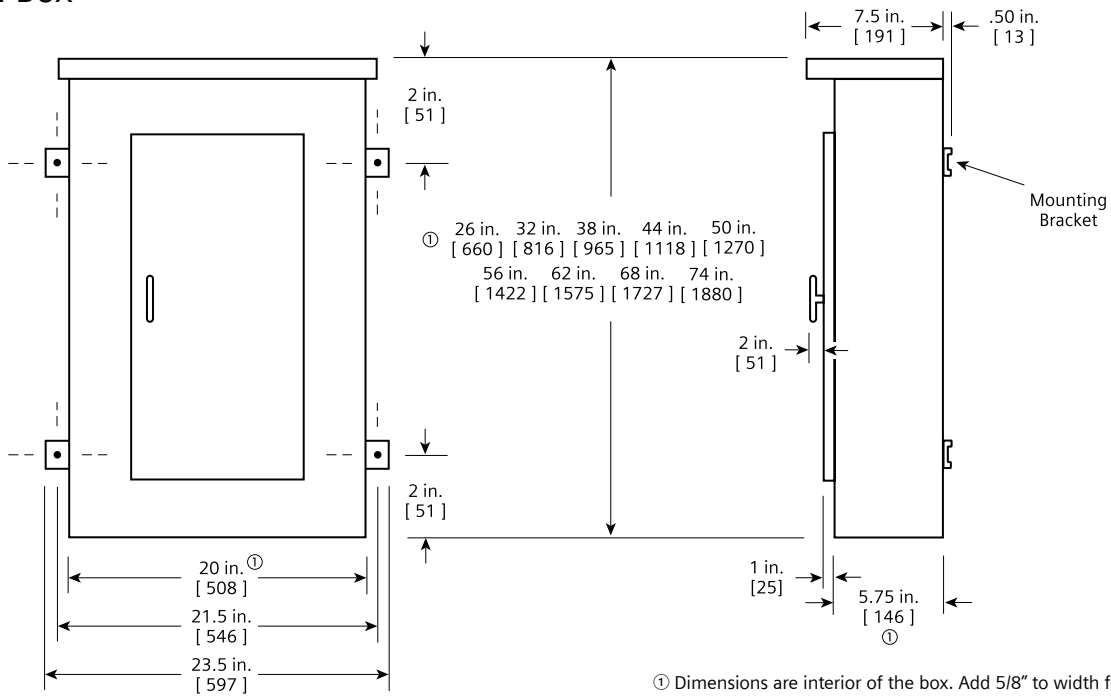

① Dimensions are interior of the box. Add 5/8" to width for absolute dimension. Add 1/8" to height for absolute dimension.

Dimensions shown in inches and millimeters [].

PANELBOARDS

Kits and Accessories

SELECTION

Table P2-20 – Standard Enclosures

Box Height Inches	Catalogue Number					
	Type 1 Standard Trim			Type 2 Standard Trim		Type 3R/12 (1) Complete Enclosure With Hinged Cover
	Box	Surface	Flush	Box	Surface	
26	B26	S26B	F26B	DSB52026	S26B	WP26
32	B32	S32B	F32B	DSB52032	S32B	WP32
38	B38	S38B	F38B	DSB52038	S38B	WP38
44	B44	S44B	F44B	DSB52044	S44B	WP44
50	B50	S50B	F50B	DSB52050	S50B	WP50
56	B56	S56B	F56B	DSB52056	S56B	WP56
62	B62	S62B	F62B	DSB52062	S62B	WP62
68	B68	S68B	F68B	DSB52068	S68B	WP68
74	B74	S74B	F74B	DSB52074	S74B	WP74

Options for Type 1 & 2 Tubs

Add suffix "K" for enclosure c/w tub end wall with knockouts

Add suffix "KN" for enclosure c/w tub end wall with knockouts and gasketed

Add suffix "N" for enclosure gasketed

Add suffix "P" for enclosure painted std grey

Add suffix "PK" for enclosure painted std grey c/w tub end wall with knockouts

Add suffix "PKN" for enclosure painted std grey c/w tub end wall with knockouts and gasketed

Add suffix "PN" for enclosure painted std grey and gasketed

Add suffix "M" for metal card holder

Hinged trim - Replace "B" suffix with "H"

Door-in-door - Replace "B" suffix with "D"

Metal card holder – Add "M" suffix

Option For 24" Wide Enclosures with Equal Gutter on Both Sides

24" wide with equal gutter on both sides - Add "24" as prefix

(1) For Silicon free enclosure, contact local Siemens representative.

Table P2-21 – Breaker Kits and Accessories (1)

Kit No.	Description	Contents
BBKB32AT	BL/BQD 6-pole 3" branch breaker kit	Kit contains top barrier, (3) A/C connectors, (1) B connector, hardware (Al/Tin)
BBKB32	BL/BQD6 6-pole 3" branch breaker kit	Kit contains top barrier, (3) A/C connectors, (1) B connector, hardware (Cu/Tin)
BBKB32CS	BL/BQD 6-pole 3" branch breaker kit	Kit contains top barrier, (3) A/C connectors, (1) B connector, hardware (Cu/Silver)
BBKED32AT	ED 6-pole 3" branch breaker kit	Kit contains breaker support, inter-phase barriers, (3) A/C connectors, (1) B connector, hardware (Al/Tin)
BBKED32	ED 6-pole 3" branch breaker kit	Kit contains breaker support, inter-phase barriers, (3) A/C connectors, (1) B connector, hardware (Cu/Tin)
BBKED32CS	ED 6-pole 3" branch breaker kit	Kit contains breaker support, inter-phase barriers, (3) A/C connectors, (1) B connector, hardware (Cu/Silver)
BBKQ1AT	QJ branch breaker kit for 2 and 3-pole single mount	Kit to contain all connectors and cover plates necessary to mount both 2 and 3-pole breakers (Al/Tin)
BBKQ1	QJ branch breaker kit	Kit to contain all connectors and cover plates necessary to mount both 2 and 3-pole breakers (Cu/Tin)
BBKQ1CS	QJ branch breaker kit for 2 and 3-pole single mount	Kit to contain all connectors and cover plates necessary to mount both 2 and 3-pole breakers (Cu/Silver)
DFK1	BL, BQD, ED deadfront kit for 1" pole breakers	Center strips 3", 6", 9", 15," 21" plus mounting hardware
DFFP3	Deadfront filler 3"	3" empty space filler and hardware
DFFP6	Deadfront filler 6"	6" empty space filler and hardware
BNK2	Branch neutral (P2)	Three tier lug with mounting hardware to increase neutral capacity
P2BK1	P2 250A max. Bonding Kit	Bonding strap and hardware
P2BK2	P2 400A max. Bonding Kit	Bonding strap and hardware
P2BK3	P2 600A max. Bonding Kit	Bonding strap and hardware
MHKP2	Truck kit for P2	Trim screws, clips, directory cards, ground bars, interior adjusting kit, bounding kit, number strip
BBKCED32	CED6 branch breaker kit	Connector kit for P2, 24"W, 400A Cu/Tin bus only
BBKCED32CS	CED6 branch breaker kit	Connector kit for P2, 24"W, 400A Cu/Silver bus only

(1) For CED6 branch breaker kit, contact local Siemens representative

PANELBOARDS

Circuit Breaker / Lighting and Distribution

Type S3

600 Volts AC, 250 Volts DC Maximum
600 Ampere Mains
400 Ampere Maximum Branch
UL & CSA Short Circuit Rating –
200,000A IR Maximum

Feed-thru and subfeed lugs may result in lower interrupting ratings if not protected by a main device. Consult sales office.

Meets 1996 NEC wire bending requirement, Section 373-6, CSA - C22.2 No. 0.12.

Panelboards

Listed by Underwriters' Laboratories, Inc., under "Panelboards" File #E2269 for interiors and #E4016 for boxes and fronts & CSA File #LR93833.

Service

600 Volts AC, 250 Volts DC, Maximum.
 1 Phase, 3 Wire;
 3 Phase, 3 Wire; or 3 Phase, 4 Wire.

Panelboard Fronts and Doors

Standard panelboards are furnished with trim that features concealed fasteners and hinges with a flush door lock. All are factory assembled for ease of installation. Fronts are fabricated from code gauge steel and finished ASA61.

Main Breakers

BL, BLH, HBL, BQD6, ED4, ED6, HED4, HED6, CED6, QJ2, QJH2, QJ2-H, FXD6, FD6, HFD6 frame main breakers are mounted horizontally. CFD6, JXD6, JD6, HJD6, SJD6, LXD6, LD6, and SLD6 main breakers are mounted vertically. The CFD6, JD6, HJD6, LD6 and HLD6 will be mounted at top only.

Main Breaker Panel Connectors

Ampere Rating	Connectors Suitable for Cu or Al
125	(1) — #14-1/0 AWG
225	(1) — #4 AWG-300 mcm
400	(2) — #3/0 AWG-500 mcm Cu or (2) — #4/0 AWG-250 mcm Al
600	(2) — #3/0-500 mcm Cu or (2) — #4/0-500 mcm Al

Connector ranges indicated do not apply to all main breaker types. Refer to molded case circuit breaker standard pressure wire connector chart for the connector range of a specific frame.

Main Lug Connectors

100	(1) — #12-1/0 AWG
225	(1) — #6 AWG-300 mcm
400	(1) — 250-500 mcm or (2) — #3/0 AWG-250 mcm
600	(2) — #3/0 AWG-500 mcm

Branch Breaker Symmetrical Interrupting Capacity

Based on Underwriters' Test Procedure

Meet Federal Specification W-C375b dated July 22, 1975.

Boxes

20" wide, 5.75" deep (100A, 225A and 400A panel)
 20" wide, 7.75" deep (600A)

Gutters

Ampere Rating	Main Lug	Main Breaker
125	5.5	5.75
225	7.0	5.0
400	11.0	14.0
600	14.0	15.5

Branch Breaker Side Gutters

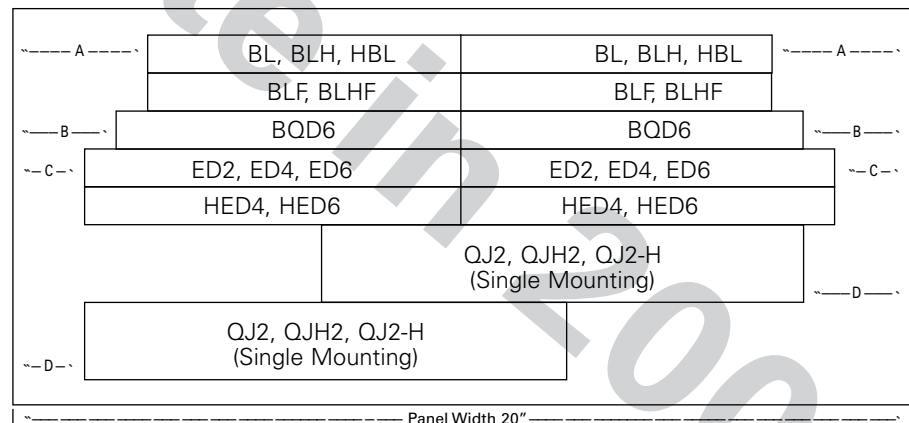

Side Gutter Wiring Space (inches)

Reference Point	Panel Width 20"
A	5.75"
B	5.125"
C	4.0"
D	5.0"

Series Connected Short Circuit Ratings®

The term "Series Connected Short Circuit Rating" refers to the application of series connected circuit breakers in a combination that allows some breakers to have lower individual interrupting

ratings than the available fault current. This is permitted as long as the series combination has been tested and certified by UL & CSA.

Series ratings must be specified on order at time of entry.

®For Series Ratings see Series Rating Guide.

Circuit Breaker / Lighting and Distribution

Type S3

Shown with Standard Mains, Top Fed and Surface Trim

Catalog number is for aluminum main bus. For optional copper main bus change "A" in position 11 to "C".

Panels are top feed, surface mounted. For bottom feed, change "T" in position 12 to "B". For flush mounting, change "S" in position 13 to "F".

Replace sixth and seventh position in panelboard catalog number, with main breaker catalog number. Use price adders from main breaker section table. Horizontally mounted.

Main Lugs Only – shown with aluminum bus, top fed and surface trim

Maximum Panel Amp. Rating	Maximum 1-Pole Circuits	120/240Volts		240 Volts		120/208 Volts	
		1 Phase, 3 Wire Catalog Number		3 Phase, 3 Wire Catalog Number		3 Phase, 4 Wire Catalog Number	
125	18 (9")	S3A18ML125ATS		S3D18ML125ATS		S3C18ML125ATS	
	24 (12")	S3A24ML125ATS		S3D24ML125ATS		S3C24ML125ATS	
	30 (15")	S3A30ML125ATS		S3D30ML125ATS		S3C30ML125ATS	
	36 (18")	S3A36ML125ATS		S3D36ML125ATS		S3C36ML125ATS	
	42 (21")	S3A42ML125ATS		S3D42ML125ATS		S3C42ML125ATS	
	48 (24")	S3A48ML125ATS		S3D48ML125ATS		S3C48ML125ATS	
	54 (27")	S3A54ML125ATS		S3D54ML125ATS		S3C54ML125ATS	
	60 (30")	S3A60ML125ATS		S3D60ML125ATS		S3C60ML125ATS	
	66 (33")	S3A66ML125ATS		S3D66ML125ATS		S3C66ML125ATS	
72 (36")	S3A72ML125ATS		S3D72ML125ATS		S3C72ML125ATS		
225 or 250*	18 (9")	S3A18ML225ATS		S3D18ML225ATS		S3C18ML225ATS	
	24 (12")	S3A24ML225ATS		S3D24ML225ATS		S3C24ML225ATS	
	30 (15")	S3A30ML225ATS		S3D30ML225ATS		S3C30ML225ATS	
	36 (18")	S3A36ML225ATS		S3D36ML225ATS		S3C36ML225ATS	
	42 (21")	S3A42ML225ATS		S3D42ML225ATS		S3C42ML225ATS	
	48 (24")	S3A48ML225ATS		S3D48ML225ATS		S3C48ML225ATS	
	54 (27")	S3A54ML225ATS		S3D54ML225ATS		S3C54ML225ATS	
	60 (30")	S3A60ML225ATS		S3D60ML225ATS		S3C60ML225ATS	
	66 (33")	S3A66ML225ATS		S3D66ML225ATS		S3C66ML225ATS	
72 (36")	S3A72ML225ATS		S3D72ML225ATS		S3C72ML225ATS		
400	18 (9")	S3A18ML400ATS		S3D18ML400ATS		S3C18ML400ATS	
	24 (12")	S3A24ML400ATS		S3D24ML400ATS		S3C24ML400ATS	
	30 (15")	S3A30ML400ATS		S3D30ML400ATS		S3C30ML400ATS	
	36 (18")	S3A36ML400ATS		S3D36ML400ATS		S3C36ML400ATS	
	42 (21")	S3A42ML400ATS		S3D42ML400ATS		S3C42ML400ATS	
	48 (24")	S3A48ML400ATS		S3D48ML400ATS		S3C48ML400ATS	
	54 (27")	S3A54ML400ATS		S3D54ML400ATS		S3C54ML400ATS	
	60 (30")	S3A60ML400ATS		S3D60ML400ATS		S3C60ML400ATS	
	66 (33")	S3A66ML400ATS		S3D66ML400ATS		S3C66ML400ATS	
72 (36")	S3A72ML400ATS		S3D72ML400ATS		S3C72ML400ATS		
600	18 (9")	S3A18ML600ATS		S3D18ML600ATS		S3C18ML600ATS	
	24 (12")	S3A24ML600ATS		S3D24ML600ATS		S3C24ML600ATS	
	30 (15")	S3A30ML600ATS		S3D30ML600ATS		S3C30ML600ATS	
	36 (18")	S3A36ML600ATS		S3D36ML600ATS		S3C36ML600ATS	
	42 (21")	S3A42ML600ATS		S3D42ML600ATS		S3C42ML600ATS	
	48 (24")	S3A48ML600ATS		S3D48ML600ATS		S3C48ML600ATS	
	54 (27")	S3A54ML600ATS		S3D54ML600ATS		S3C54ML600ATS	
	60 (30")	S3A60ML600ATS		S3D60ML600ATS		S3C60ML600ATS	
	66 (33")	S3A66ML600ATS		S3D66ML600ATS		S3C66ML600ATS	
72 (36")	S3A72ML600ATS		S3D72ML600ATS		S3C72ML600ATS		

Notes:

- * Complete part number shown with standard main lugs (ML) included in price, Top feed and Surface trim mounted.
- * Pricing based on aluminum bus, for Copper Bus, change prefix 'A' to 'C' on catalog number and contact your local sales office for pricing.
- * For DC applications use 1 phase 3 wire base pricing and change voltage prefix 'A' to 'O' (250V DC) or 'N' (250V DC).
- * See pages 6/18 and 6/19 for field and factory modifications.
- * Panel is rated 250 Amps when used as "FD" style Main Breaker.



Circuit Breaker / Lighting and Distribution

Type S3

Shown with Standard Mains, Top Fed and Surface Trim

Catalog number is for aluminum main bus. For optional copper main bus change "A" in position 11 to "C".

Panels are top feed, surface mounted. For bottom feed, change "T" in position 12 to "B". For flush mounting, change "S" in position 13 to "F".

Replace sixth and seventh position in panelboard catalog number, with main breaker catalog number. Use price adders from main breaker section table. Horizontally mounted.

Main Lugs Only – shown with aluminum bus, top fed and surface trim

Maximum Panel Amp. Rating	Maximum 1-Pole Circuits	480 Volts	277/480 Volts	600 Volts or 250 VDC Max.®	347/600 Volts
		1 Phase, 3 Wire Catalog Number	3 Phase, 4 Wire Catalog Number	3 Phase, 3 Wire Catalog Number	3 Phase, 4 Wire Catalog Number
125	18 (9")	S3F18ML125ATS	S3E18ML125ATS	S3G18ML125ATS	S3L18ML125ATS
	24 (12")	S3F24ML125ATS	S3E24ML125ATS	S3G24ML125ATS	S3L24ML125ATS
	30 (15")	S3F30ML125ATS	S3E30ML125ATS	S3G30ML125ATS	S3L30ML125ATS
	36 (18")	S3F36ML125ATS	S3E36ML125ATS	S3G36ML125ATS	S3L36ML125ATS
	42 (21")	S3F42ML125ATS	S3E42ML125ATS	S3G42ML125ATS	S3L42ML125ATS
	48 (24")	S3F48ML125ATS	S3E48ML125ATS	S3G48ML125ATS	S3L48ML125ATS
	54 (27")	S3F54ML125ATS	S3E54ML125ATS	S3G54ML125ATS	S3L54ML125ATS
	60 (30")	S3F60ML125ATS	S3E60ML125ATS	S3G60ML125ATS	S3L60ML125ATS
225 or 250*	66 (33")	S3F66ML125ATS	S3E66ML125ATS	S3G66ML125ATS	S3L66ML125ATS
	72 (36")	S3F72ML125ATS	S3E72ML125ATS	S3G72ML125ATS	S3L72ML125ATS
	18 (9")	S3F18ML225ATS	S3E18ML225ATS	S3G18ML225ATS	S3L18ML225ATS
	24 (12")	S3F24ML225ATS	S3E24ML225ATS	S3G24ML225ATS	S3L24ML225ATS
	30 (15")	S3F30ML225ATS	S3E30ML225ATS	S3G30ML225ATS	S3L30ML225ATS
	36 (18")	S3F36ML225ATS	S3E36ML225ATS	S3G36ML225ATS	S3L36ML225ATS
	42 (21")	S3F42ML225ATS	S3E42ML225ATS	S3G42ML225ATS	S3L42ML225ATS
	48 (24")	S3F48ML225ATS	S3E48ML225ATS	S3G48ML225ATS	S3L48ML225ATS
400	54 (27")	S3F54ML225ATS	S3E54ML225ATS	S3G54ML225ATS	S3L54ML225ATS
	60 (30")	S3F60ML225ATS	S3E60ML225ATS	S3G60ML225ATS	S3L60ML225ATS
	66 (33")	S3F66ML225ATS	S3E66ML225ATS	S3G66ML225ATS	S3L66ML225ATS
	72 (36")	S3F72ML225ATS	S3E72ML225ATS	S3G72ML225ATS	S3L72ML225ATS
	18 (9")	S3F18ML400ATS	S3E18ML400ATS	S3G18ML400ATS	S3L18ML400ATS
	24 (12")	S3F24ML400ATS	S3E24ML400ATS	S3G24ML400ATS	S3L24ML400ATS
	30 (15")	S3F30ML400ATS	S3E30ML400ATS	S3G30ML400ATS	S3L30ML400ATS
	36 (18")	S3F36ML400ATS	S3E36ML400ATS	S3G36ML400ATS	S3L36ML400ATS
600	42 (21")	S3F42ML400ATS	S3E42ML400ATS	S3G42ML400ATS	S3L42ML400ATS
	48 (24")	S3F48ML400ATS	S3E48ML400ATS	S3G48ML400ATS	S3L48ML400ATS
	54 (27")	S3F54ML400ATS	S3E54ML400ATS	S3G54ML400ATS	S3L54ML400ATS
	60 (30")	S3F60ML400ATS	S3E60ML400ATS	S3G60ML400ATS	S3L60ML400ATS
	66 (33")	S3F66ML400ATS	S3E66ML400ATS	S3G66ML400ATS	S3L66ML400ATS
	72 (36")	S3F72ML400ATS	S3E72ML400ATS	S3G72ML400ATS	S3L72ML400ATS
	18 (9")	S3F18ML600ATS	S3E18ML600ATS	S3G18ML600ATS	S3L18ML600ATS
	24 (12")	S3F24ML600ATS	S3E24ML600ATS	S3G24ML600ATS	S3L24ML600ATS
600	30 (15")	S3F30ML600ATS	S3E30ML600ATS	S3G30ML600ATS	S3L30ML600ATS
	36 (18")	S3F36ML600ATS	S3E36ML600ATS	S3G36ML600ATS	S3L36ML600ATS
	42 (21")	S3F42ML600ATS	S3E42ML600ATS	S3G42ML600ATS	S3L42ML600ATS
	48 (24")	S3F48ML600ATS	S3E48ML600ATS	S3G48ML600ATS	S3L48ML600ATS
	54 (27")	S3F54ML600ATS	S3E54ML600ATS	S3G54ML600ATS	S3L54ML600ATS
	60 (30")	S3F60ML600ATS	S3E60ML600ATS	S3G60ML600ATS	S3L60ML600ATS
	66 (33")	S3F66ML600ATS	S3E66ML600ATS	S3G66ML600ATS	S3L66ML600ATS
	72 (36")	S3F72ML600ATS	S3E72ML600ATS	S3G72ML600ATS	S3L72ML600ATS

Notes:

- Complete part number shown with standard main lugs(ML) included in price, Top feed and Surface mounted.
- Pricing based on Aluminum bus, For Copper Bus, change prefix 'A' to 'C' on catalog number and contact your local sales office for pricing.
- For DC applications use 3 phase 3 wire base pricing and change voltage prefix 'G' to 'O' (250VDC) or 'N' (125VDC)
- See pages 6/18 and 6/19 for field and factory modifications.
- Panel is rated 250 Amps when used as a "FD" style Main Breaker.

PANELBOARDS

Modifications and Additions

Type S3^①

When required, special constructions or additions to standard panelboards may be specified for all **factory-assembled** Lighting and Distribution Panelboards. Below and on the next page are listed many of those available for S3 panelboards. In no case do these apply to **Narrow** (Column) Width Lighting Panelboards.

1. Miscellaneous

Description	
Type 2 or (Drip-proof)	Consult Sales
Type 3R or 12 Enclosure ^②	
Box Ends c/w Knock-Outs	

2. Corflex Plates

Alum. or Fiber	Consult Sales
--------------------------	---------------

3. Gasketed — (No Knockouts)

Type 1A Gaskets for Trim and Door	Consult Sales
---	---------------

4. For Boxes With Other Than Standard Dimensions^③

For each 6" increase in height 24" wide	Consult Sales	Consult Sales
Barrier in gutter, add to extra gutter price.		

5. Painted Finish

Standard Color (ASA-61) — box only.	Consult Sales
---	---------------

6. Special Front and Door Arrangements^④

Front Hinged to Box — Standard Door Over Interior, hinged front exposes wiring gutter	Consult Sales
Door-in-Door Construction (surface or flush)	

7. Front and Door Accessories

Nameplate — laminated, engraved	Consult Sales
Metal Card Holder	

8. Increased Capacity Neutral^{⑤⑥}

Amperage Rating	Phase	Neutral		Unit Space (inches)
125		225		3
225		400		6
225		600	Consult Sales	12 ^{⑤⑥}
400		600		6 ^{⑤⑥}
400		800		9 ^{⑤⑥}
600		800		9 ^{⑤⑥}

9. Grounding of Panelboards (Add to Base Price)^⑦

Non-Insulated Equipment Ground Bar	Consult Sales
Copper Non-Insulated Ground Bar	
Al Insulated Equipment Ground Bar	
Cu Insulated Equipment Ground Bar	

10. Subfeed, Feed-Thru

Ampere Rating	List Price \$		Connector Cu / Al Wire Range	Unit Space (inches) ^⑧
	3-Pole	2-Pole		

Subfeed (Double) Lugs for Main Lug Panelboards Only^⑨

125	Consult Sales	Consult Sales	(2) — #12-1/0 AWG	3
225			(2) — #4 AWG-300 mcm	6

Feed-Thru Lugs^{⑩⑪}

125	Consult Sales	Consult Sales	(1) — #12-1/0 AWG	3
225			(1) — #6 AWG-300 mcm	
400	Consult Sales	Consult Sales	(1) — 250-500 mcm	9
			(2) — #3/0 AWG-250 mcm	
600 ^⑩	Consult Sales		(2) — 250-500 mcm	12

11. MLO Compression Lugs — Copper or Aluminum Cable^⑫

Available as main lugs and neutral lug. Price includes required aluminum compression lugs and extra gutter space.

Ampere Rating		Box Height (inches)
125	Available in Aluminum or Copper	3
225		3
400 ^⑬		9
600 ^⑬		6

12. Multi-Section Panels

a) Double Section Panels-Cross Over Cable. Cable NOT Included.

225 amps maximum per pannel	Consult Sales
400 amps maximum per pannel	
600 amps maximum per pannel	

b) Double Section Panels - Cross Over bus: Refer to Siemens

c) Triple Section Panels: Refer to Siemens

Standard Branch Neutral Lugs for BL breakers

Panel Type	No. of cct	Wire Size - Branch Neutral Lugs	Quantities
S3 Condo	48cct	#14 - 1/0 Al.	32 x #14-1/0
	66cct	#14 - 1/0 Al.	32 x #14-1/0

①Consult sales office for appropriate multiplier.

②Specify Type 3R or 12 on order entry.

③Panels having doors over 56" high, 2 semi-flush locks are standard.

④Cannot exceed 48" wide.

⑤Not available with feed-thru lugs or subfeed lugs.

⑥Except where noted, ground bus is **not installed** in panel box, but shipped with interior.

⑦Add to unit space dimension in Box Selection Table.

⑧Not available in panels with subfeed breakers.

⑨Requires 20" wide and 7.75" deep box.

⑩Must specify actual cable size.

⑪Consult sales office for price and availability.

Modifications and Additions

Type S3^①

13. Remote Control Switches — 600V AC^② Bus connected

Ampere Rating	2-Pole		3-Pole	
	2-Pole	3-Pole	2-Pole	3-Pole
30	ASCO 920		Siemens CLH	
60	Mechanically Held ^{③④⑤}		Electrically Held ^{⑥⑦}	
75				
100				
150				
200				
225				

14. Service Entrance Barrier Kits

Ampere Rating	Breaker Type	Catalog Number
70	BQD6	CSBQDSE
100	BL, BLH, HBL	CSBLSE
125	ED2, ED4, ED6, HED6	CSESE
225	QJ2, QJH2, QJ2H	CSQJSE
250	FXD6, FD6, HFD6	CSFDSE
400	JXD2, JXD6, JD6, HJD5	CSJLSE
600	LXD6, LD6, HLD6	CSJLSE

15. Ground Fault Sensing Relay Kit^⑧ — Equipment Protection (30 MA)

For Use with Breaker Type	Number of Poles	Description	
ED2, ED4, ED6, HED4,	1, 2, 3	Basic Kit	Consult Sales
		Basic Kit with Normally Open Bell Alarm	
		Basic Kit with Normally Closed Bell Alarm	

16. Circuit Breaker Accessories

Breaker Type

Handle Blocking Device Blocks handle in either the "ON" or "OFF" position

BL, BLH, HBL
QJ2, QJH2, QJ2-H
BQD6
ED4, ED6, HED4, CED6
FXD6, HFD6, CFD6
JXD6, HJD6, SJD6, LXD6, SLD6

Padlocking Device — Padlocks in "OFF" position

BL, HBL, BLH
QJ2, QJH2, QJ2-H
BQD6
ED4, ED6, HED4, CED6
FXD6, HFD6, CFD6
JXD6, HJD6, SJD6, LXD6, SLD6

17. Main Bus^{⑨⑩}

Standard main bus, is tin plated aluminum. For copper main bus consult sales.

18. Copper Lugs — For Main Lug Only Panels

Standard main lugs and neutral lugs are tin finished aluminum, UL & CSA listed for use with aluminum/copper cables. For copper lugs in the mains and neutral for use with copper cables only consult sales.

19. Shunt Trip on Main or Branch^⑪

BL, BLH, HBL, BQD6
QJ2, QJ2H, QJH2,
ED4, ED6, HED4,
All Others

① Consult sales office for appropriate multiplier.

② Control voltage must be specified and one line diagram must accompany order.

③ Devices listed by Underwriters' Laboratories, Inc. When 2-wire control is required for Relay and Terminal Block (9" of unit space required).

④ For short circuit ratings with remote control switches, consult sales office.

⑤ Unit space 12" for mechanically held contactors and 18" for electrically held contactors.

⑧ Panelboard short circuit rating is limited to 5000 rms symmetrical.

⑨ Requires 20" wide 7.75" deep box.

⑩ Box depth will be 10" minimum.

⑪ Includes space for mounting clock only.

Other modifications may require more space. Consult local sales office.

⑫ Price does not include control power transformer.

⑬ Replace "A" in position 11 in catalog number.

⑭ S3, 100, 225A copper is unplated.

⑮ S3, 100 and 225A copper is unplated for silver plated contact sales.

⑯ Tin finished aluminum. Silver finish not available.

⑰ "BL", "BQD" and "ED" frame main with shunt trip, add 3" to box height; as branch, add 1" per breaker.

⑱ Not CSA approved.

Power and Distribution

Type S5 (SPP6)

**600 Volts AC, 250 Volts DC Maximum
1200 Ampere Mains
1200 Ampere Maximum Branch
UL & CSA Short Circuit Rating —
200,000A IR Maximum**

**Branch Breaker Symmetrical
Interrupting Capacity**

Based on Underwriters' Test Procedure

Meets 1996 NEC wire bending requirement, section 373-6.
CSA - C22.2 No. 0.12

Panelboards

Listed by Underwriters' Laboratories, Inc., under "Panelboards" File #E2269 for interiors and #E4016 for boxes and fronts.

Meet Federal Specification W-C375B/Gen. & CSA File #LR93833.

Service

600 Volts AC, 250 Volts DC, Maximum.
1 Phase, 3 Wire; 3 Phase, 3 Wire; or
or 3 Phase, 4 Wire.

Panelboard Fronts and Doors

Standard panelboards are furnished with 4 piece trim with ventilation. Fronts are fabricated from code gauge steel and finished ASA61.

Main Breakers

All 400A and 1200A frame main breakers are mounted horizontally.

Main Lug Connectors

Ampere Rating	Connectors Suitable for Cu or Al
400	(1)-#3/0 AWG-500MCM
400	(2)-#3/0 AWG-250MCM
600	(2)-#3/0 AWG-500MCM
800	(3)-#3/0 AWG-500MCM
1200	(4)-#3/0 AWG-500MCM

End Gutters

Ampere Rating	Main Lug (inches)	Main Breaker (inches)
400/600	15.967	13.0
800/1200	15.967	13.0

Boxes

38" wide, 12.75" deep (Type 1)
38" wide, 14.25" deep (Type 3R/12)

Integrated Equipment Short Circuit Ratings

The term "Integrated Equipment Short Circuit Rating" refers to the application of series connected circuit breakers in a combination that allows some breakers to have lower individual interrupting ratings than the available fault current. This is permitted as long as the series combination has been tested and certified by UL & CSA.

Series ratings must be specified on order at time of entry.

Panelboard Specifications

Maximum Panel Ampere	Unit Space (MLO)	Box Height				
400A	30"	60"	120/240Volts 1 Phase, 3 Wire	120/208 Volts 3 Phase, 4 Wire	600 Volts 3 Phase, 3 Wire	347/600 Volts 3 Phase, 4 Wire
600A	45"	75"				
800A	60"	90"				
1200A						

Branch Breaker Side Gutters

~A~	BL BLH, HBL	BL BLH, HBL
~B~	ED4, ED6 HED4	ED4, ED6 HED4
~C~	QJ2, QJH2 QJ2H	QJ2, QJH2 QJ2H
~D~	FXD6, FD6 HFD6	FXD6, FD6, HFD6
~E~	JXD6, JD6 HJD6	JXD6, JD6 HJD6
~F~	CED6	CED6
~G~	CFD6	
~H~	JXD6, JD6, LXD6, LD6, SLD6 HJD6, SJD6, HLD6	
~I~	CJD6, CLD6	
~J~	MD6, ND6, CMD6, CND6, HMD6, HND6	
~K~	SMD6, SND6	
~M~	LMD6, HLMD6	

Reference Letter	Panel Width (inches)
	38 (S5)
A	14.0
B	10.0
C	8.75
D	8.25
E	7.925
F	7.615
G	11.769
H	13.425
I	8.956
J	13.0
K	12.0
M	13.0



Power and Distribution

Main Breaker Selection

Ampere Rating	Breaker Type	Catalog Number	Maximum Interrupting Rating (KA)			Available Trip Values
			240V	480V	600V	
400	JXD6	JX	65	35	25	200, 225, 250, 300, 350, 400
	JD6	J6	65	35	20	200, 225, 250, 300, 350, 400
	HJD6	HJ	100	65	35	200, 225, 250, 300, 350, 400
	CJD6	CJ	200	150	100	200, 225, 250, 300, 350, 400
	SJD6	SJ	65	35	25	200, 300, 400
600	LXD6	LX	65	35	25	450, 500, 600
	LD6	L6	65	35	25	250, 300, 350, 400, 450, 500, 600
	HLD6	HL	100	65	35	250, 300, 350, 400, 450, 500, 600
	CLD6	CL	200	150	100	450, 500, 600
	SLD6	SL	65	35	25	300, 400, 500, 600
800	MD6	M6	65	50	25	500, 600, 700, 800
	HMD6	HM	100	65	50	500, 600, 700, 800
	CMD6	CM	200	100	65	500, 600, 700, 800
	SMD6	SM	65	50	25	600, 700, 800
1200	ND6	N6	65	50	25	800, 900, 1000, 1200
	HND6	HN	100	65	50	800, 900, 1000, 1200
	CND6	CN	200	100	65	900, 1000, 1200
	SND6	SN	65	50	25	900, 1000, 1200

Branch Circuit Breaker Selection^①

Breaker Type	Available Trip Value Ampere Ratings	Mounting Height Inches (mm)			Max IC Rating (KA)		
		Twin	Single	Gutter ^②	240V	480V	600V
BL	15, 20, 30, 40, 50, 60, 70, 80, 90, 100	3.75" (95) ^③	—	A	10	—	—
BLF (GFCI)	15, 20, 30, 40, 50, 60	3.75" (95) ^③	—	A	10	—	—
BLE (GFCI)	15, 20, 30	3.75" (95) ^③	—	A	10	—	—
BLH	15, 20, 30, 40, 50, 60, 70, 80, 90, 100	3.75" (95) ^③	—	A	22	—	—
BLH (GFCI)	15, 20, 30, 40, 50, 60	3.75" (95) ^③	—	A	22	—	—
BQD6 ^④	15, 20, 30, 40, 50, 60, 70	3.75" (95) ^③	—	A	65	—	10
ED2	15, 20, 30, 40, 50, 60, 70, 80, 90, 100	3.75" (95) ^③	3.75" (95) ^③	B	10	—	—
ED4	15, 20, 30, 40, 50, 60, 70, 80, 90, 100, 110, 125	3.75" (95) ^③	3.75" (95) ^③	B	65	18	—
ED6	15, 20, 30, 40, 50, 60	3.75" (95) ^③	3.75" (95) ^③	B	100	18	18
	70, 80, 90, 100, 110, 125	3.75" (95) ^③	3.75" (95) ^③	B	100	42	18
CED6	15, 20, 30, 40, 50, 60, 70, 80, 90, 100	3.75" (95) ^③	3.75" (95) ^③	F	200	200	100
	110, 125	—	3.75" (95) ^③	F	—	—	100
QJ2	60, 70, 80, 90, 100, 125, 150, 175, 200, 225	5" (127) ^⑤	5" (127)	C	10	—	—
QJH2	60, 70, 80, 90, 100, 125, 150, 175, 200, 225	5" (127)	5" (127)	C	22	—	—
QJ2-H	60, 70, 80, 90, 100, 125, 150, 175, 200, 225	5" (127) ^⑤	5" (127)	C	42	—	—
FXD6	70, 80, 90, 100, 125, 150, 175, 200, 225, 250	5" (127) ^⑤	5" (127)	D	65	35	—
HFD6	70, 80, 90, 100, 125, 150, 175, 200, 225, 250	5" (127) ^⑤	5" (127)	D	100	65	—
CFD6	70, 80, 90, 100, 125, 150, 175, 200, 225, 250	—	5" (127)	G	200	200	—
JXD2	200, 225, 250, 300, 350, 400	8.75" (222) ^⑥	8.75" (222)	E	65	—	—
	200, 225, 250, 300, 350, 400	8.75" (222) ^⑥	8.75" (222)	E	65	35	25
	200, 225, 250, 300, 350, 400	8.75" (222) ^⑥	8.75" (222)	E	100	65	35
	200, 225, 250, 300, 350, 400	—	8.75" (222)	I	200	150	100
	200, 300, 400	—	8.75" (222)	H	65	35	25
SHJD6 ^④	200, 300, 400	—	8.75" (222)	H	100	65	35
	200, 300, 400	—	8.75" (222)	I	200	150	100
LXD6, LD6	450, 500, 600	—	8.75" (222)	H	65	35	25
	250, 300, 350, 400, 450, 500, 600	—	8.75" (222)	H	100	65	35
	450, 500, 600	—	8.75" (222)	I	200	150	100
	300, 400, 500, 600	—	8.75" (222)	H	65	35	25
	300, 400, 500, 600	—	8.75" (222)	H	100	65	35
SCLD6 ^④	300, 400, 500, 600	—	8.75" (222)	I	200	150	100
	—	—	8.75" (222)	I	—	—	—
LMD6	500, 600, 700, 800	—	8.75" (222)	M	65	50	25
	500, 600, 700, 800	—	8.75" (222)	M	100	65	50
MD6	500, 600, 700, 800	—	10" (254)	J	65	35	25
	500, 600, 700, 800	—	10" (254)	J	100	65	35
	500, 600, 700, 800	—	10" (254)	J	200	150	100
	600, 700, 800	—	10" (254)	K	65	35	25
	600, 700, 800	—	8.75" (222)	H	100	65	50
	500, 600, 800	—	8.75" (222)	I	200	100	65
ND6	800, 900, 1000, 1200	—	10" (254)	J	65	50	25
	800, 900, 1000, 1200	—	10" (254)	J	100	65	35
	800, 900, 1000, 1200	—	10" (254)	J	200	150	100
	800, 1000, 1200	—	10" (254)	K	65	35	25
SHND6 ^④	800, 900, 1000, 1200	—	8.75" (222)	H	100	65	50
	800, 900, 1000, 1200	—	8.75" (222)	I	200	100	65

Branch Breaker Gutter Dimensions For 38"W Distribution Section

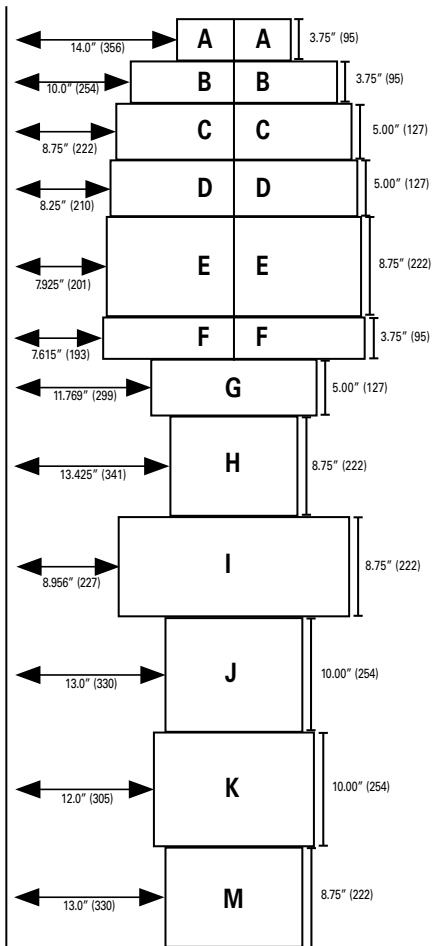

① Space includes housing frame plate with blank cover plate. Provision includes all necessary mounting hardware, less circuit breaker, and includes housing frame cover plate with breaker handle opening.
 ② 1 to 6 poles may be mounted in 3.75" (95) of unit space.
 ③ Accessories such as shunt trips on three pole breakers require 6.25" (159) of unit space.
 ④ Ground fault is not available on branch Sensitrip breakers.
 ⑤ Also 10KA at 600Y/347 Volts.
 ⑥ Refer to Table 5 for layout dimensions.

Modifications and Additions

Type S5 (SPP6)

When required, special constructions or additions to standard panelboards may be specified for all **factory-assembled** Power and Distribution Panelboards. Below and on the next page are listed many of those available for Type S5 panelboards. In no case do these apply to **Narrow** (Column) Width Lighting Panelboards or **Unassembled** Panelboards.

1. Miscellaneous

NEMA TYPE
Type 1
Type 2 (Drip-proof)
Type 3R
Type 12

2. Painted Finish

Touch-Up Paint (ASA61, Light Gray) 12 oz. aerosol can, Catalog Number TUP-61
--

3. Miscellaneous Accessories

Nameplate — laminated, engraved Tamper-Resistant Screws
--

4. Devices Mounted on Gutter Cover — Includes Device, Mounting — Wired or Unwired

Toggle Switch — SPST or 3-way; 15A
Pilot Light — General Purpose, Neon or Incandescent
Pushbutton

5. Feed-Thru Lugs^① (One Set Per Panel)

Ampere Rating	Unit Space (Additional inches)		
	3-Pole	2-Pole	MLO
400			10
600	Consult Sales	Consult Sales	10
800			17.5
1200			17.5

6. Split Bus^② (Aluminum)

Number of Poles	Unit Space (Additional inches)			
	400A	600A	800A	1200A
2	Consult Sales			
3	Consult Sales			

7. MLO Compression Lugs —

Available as main lugs and neutral lug.

Ampere Rating	Aluminum (Specify Size)	Copper (Specify Size)	Deduct From Available Unit Space (inches)
400			5
600	Consult Sales	Consult Sales	5
800			5
1200			5

8. Grounding of Panelboards^③

Non-Insulated Equipment Ground Bus Including Ground Lug
Insulated Equipment Ground Bus Including Ground Lug

9. Remote Control Switches^{④⑤}

600V AC Ampere Rating	ASCO 920 Mechanically Held ^{⑥⑦}		Siemens CLH Electrically Held ^⑧	
	2-Pole	3-Pole	2-Pole	3-Pole
30	Unit space 20"		Unit space 20"	
60				
75				
100				
150 ^⑨				
200 ^⑩				
225				

10. Increased Capacity Neutral

Ampere Rating	Unit Space (inches)	
	Phase	Neutral
400	600	None
400	800	None
600	1200	None
800	1200	None

11. Circuit Breaker Accessories

Breaker Type

Handle Blocking Device Blocks handle in either the "ON" or "OFF" position. Available for:

BL, BLH, HBL, BQD6, QJ2, QJH2, QJ2-H
ED4, ED6, HED4, CED6
FXD6, FD6, HFD6, CFD6
JXD6, JD6, HJD6, CJD6, SJD6, LXD6, LD6, HLD6, CLD6, SLD6
MD6, HMD6, CMD6, SMD6, ND6, HND6, CND6, SND6

Padlocking Device — Padlocks in "OFF" position. Available for:

BL, BLH, HBL, BQD6, QJ2, QJH2, QJ2-H
ED4, ED6, HED4, CED6
FXD6, FD6, HFD6, CFD6
JXD6, JD6, HJD6, CJD6, SJD6, LXD6, LD6, HLD6, CLD6, SLD6
MD6, HMD6, CMD6, SMD6, ND6, HND6, CND6, SND6

12. Ground Fault Sensing Relay Kit[®] Equipment Protection (30 ma)

For Use with Breaker Types	Number of Poles	Description
ED4, ED6, HED4	1, 2, 3	Basic kit Basic kit with bell alarm

13. Main Bus

Standard main bus and ground bus are tin plated aluminum. For copper main bus, neutral bus and ground bus change prefix 'A' to 'C' on catalog number and contact your sales office for pricing.

14. Copper Lugs — For Main Lug Only Panels

Standard main lugs and neutral lugs are tin plated aluminum, UL & CSA listed for use with aluminum/copper cables. For copper lugs in the mains and neutral for use with copper cables only, contact sales.

15. Shunt Trip on Main and Branches

Description ^{⑪⑫⑬⑭⑮}
BL, BQD6 (branch only)
QJ2, QJ2H, QJH2, ED2, ED4, HED4 (branch only)
All others through 600A
800A and 1200A

16. Sentron TPS (TVSS Modules)

160 KA
240 KA
Options Surge Counter Remote Indicator

①For use on main lug, main breaker or main switch panels without subfeed breakers.
②For increase in panelboard height — Consult local sales office.

③Ground bar not installed in box.

④For short circuit ratings with remote control switches, consult sales office.

⑤Available in 90" high enclosure only. Unit space is 42½" with Test and Monitor Panel; 45" without Test and Monitor Panel.

⑥Not available on Sensitrip III.

⑦For required unit space — consult local sales office.

⑧Price does not include control power transformer.

⑨Price 600 Volt 7½" high units.

⑩Mounting height increases to 6.25" when shunt trip is required.

⑪Shunt Trip on 100A frame breakers increases mounting height to 6.25" for twin mounting.

⑫Not CSA approved.

Modifications, Additions Replacements for Circuit Breakers

Replacement Connecting Strap Guide

The following table may be used to obtain the proper connector kit by measuring the exterior dimensions of the panel. Every attempt has been made to make this table complete and accurate. The table is based on panels produced by ITE, Bulldog and Siemens from 1958 to present. Should any questions arise please contact your Siemens sales office for replacements.

Panelboard				
Tub Width	Depth	Panel Type	Replacement Max Amps	Note
30" - 36" - 42"	9"	OLD CDP	400	MCCB only. Use 5939 series connectors
	9.75"	OLD CDP	600	MCCB only use 5939 series connectors Refer for 800/1200A MCCB's
32" - 38"	13.75"	CDP/VB6	1200A	MCCB series 6 connectors
			600A	"VB" style units only (*)
38"	12.75"	SPP/FPP6	1200A	MCCB series 6 connectors
			600A	"VK" or "VB" style (*)

* If switch unit width is 17" it is a vacubreak. If switch unit width is 23" or 28" it is a "VK" switch.

Connecting Strap For Use With SPP/FPP, S5, F2[Ⓢ]

Breakers	Height inches (mm)	Series 6 Number
BQ, BQH, HB	3.75 (95)	6EQ6[Ⓢ]
BL, BLH, HBL, BQD, BQD6	3.75 (95)	6BL2C[Ⓢ]
ED2, ED4, ED6, HED4	3.75 (95)	6E62[Ⓢ]
CED6	3.75 (95)	6CLE2[Ⓢ]
QJ2, QJH2, QJ2H	5 (127)	6QJ2[Ⓢ]
FXD6, FD6, HFD6	5 (127)	6F62[Ⓢ]
CFD6	5 (127)	6CLF1C[Ⓢ]
JXD2, JXD6, JD2, JD6, HJD6 SJD6, SHJD6	8.75 (222)	6JJ62[Ⓢ]
CJD6, SCJD6	8.75 (222)	6CLJ1C[Ⓢ]
LXD6, LD6, HLD6, SLD6, SHLD6	8.75 (222)	6LL61C[Ⓢ]
CLD6	8.75 (222)	6CLL1C[Ⓢ]
SCLD6	8.75 (222)	6SCL61C[Ⓢ]
MD6, HMD6, CMD6, SCMD6	10 (254)	6M61C[Ⓢ]
ND6, HND6, CND6 SND6, SHND6, SCND	10 (254)	6N61C[Ⓢ]

Blank Plates[Ⓢ]

For use with Series 6 CDP Panelboards, S5, F2, FCI and FCII Switchboards.	
Height	SPP/FPP/CDP/VB 6
1.25"	6FPB01
2.50"	6FPB02
3.75"	6FPB03
5.00"	6FPB05
10.00"	6FPB10
15.00"	6FPB15

Connecting Strap Kits and Front-Filler Plates[Ⓢ]

For use with NDP-CDP-7, S3

Breakers	Catalog Number
BQD6 (S3 only)	7 BQD6-2
BL, BLH, HBL,	7 BL-2
QJ2, QJH2, 2 Pole	7 QJ2-1
QJ2, QJH2 3 Pole Single unit, Panel Mount	7 QJ3-1
QJ2, QJH2 3 Pole Double unit, Panel Mount	7 QJ3-2
EC4, ED2, ED4, ED6, HED4, HED6	7 E6-2
Filler 1 Pole	QF3-UL

Connecting Strap Kits[Ⓢ]

For OLD CDP and NDP* Panels

Breakers	Catalog Number
QJ2, QJH2, QJ2H	5939-2C
ED2, ED4, HED4	5939-7C
FXD6, FD6, HED6	5939-8C
JXD2, JXD6, JD6, HJD6(A) LXD6, LD6, HLD6	5939-9C
JXD2, JXD6, JD6, HJD6(B)	5939-11C
*FB, FD (C)	5939-14C
CED6	5939-15C
CFD6	5939-16C
CJD6	5939-17C
CLD6	5939-18C
MD6, HMD6, CMD6	5939-19C

(A) Single Branch

(B) Dual Branch

(C) Use a replacement for EE through HE frames on NDP Panel

ⓈThese are aluminum connectors. If copper required is please add suffix C.

Ⓢ3.75" (95) plate accommodates six 1-pole breakers.

Ⓢ10" (254) plate accommodates eighteen 1-pole breakers.

ⓈSeries 6 connector kits also accommodates FCI and FCII distribution interiors, CDP6 or SPP6 Series Panels.

ⓈThese connectors are available in copper only.

ⓈCan be used as fillers or in place of circuit breakers, VK or VB Switches.

Fusible / Power and Distribution

Type F2 (FPP6)

600 Volts AC, 250 Volts DC Maximum
600 Ampere Main Switch,
1200 Ampere Main Lugs Only
600 Ampere Maximum Branch
UL & CSA Short Circuit Rating —
200,000A IR Maximum

Meets 1996 NEC wire bending requirement, section 373-6.
 CSA - C22.2 No. 0.12

Panelboards

Listed by Underwriters' Laboratories, Inc., under "Panelboards" File #E2269 for interiors and #E4016 for boxes and fronts & CSA File #LR93833.

Service

600 Volts AC, 250 Volts DC, Maximum.
 1 Phase, 3 Wire; 3 Phase, 3 Wire; or 3 Phase, 4 Wire.

Boxes

38" wide, 12.75" deep, Type 1

Panelboard Fronts and Doors

Standard panelboards are furnished with 4 piece trim. Fronts are fabricated from code gauge steel and finished ASA61.

Fuses

The Proper Fuse Type for the Application is Selected Using the Following Parameters:

- Voltage Requirements
- Conductor Ampacity
- Horsepower Requirements
- Maximum Available RMS Fault Current
- UL & CSA Fuse Class

UL & CSA Fuse Classes

Class	Amperes	Volts	Interrupting Ratings	I ² t, I _p	Circuits
H (code)	1-600A	250 and 600V or less AC	10,000A	—	Less than 10,000A available
K [®]	1-600A	250 and 600V or less AC	50,000A	—	Feeder circuits
J	1-600A	600V or less	To 200,000A	I ² t-Low I _p -Low	Feeder circuits (motor load small %)
RK1	1/10-600A	600V or less 250V or less	To 200,000A	I ² t-Slightly > J I _p -Slightly > J	Feeder circuits (motor load small %)
RK5	1/10-600A	600V or less 250V or less	To 200,000A	I ² t- > RK-1 I _p - > RK-1	Motor starting currents a factor
T	1-600A	300 and 600V or less AC	To 200,000A	I ² t-Low I _p -Low	Non-motor loads
L	601-5000A	600V or less	To 200,000A	I ² t-Low I _p -Low	Feeder circuits motor loads

®Lug is single barrel construction, rated for 2-250 kcmil or 1-500 kcmil cables.

Main Switch Panel Connectors

Ampere Rating	Connectors Suitable for Cu or Al
400	(1) — #3/0 AWG-500 mcm (2) — #3/0 AWG-250 mcm
600	(2) — #3/0 AWG-500 mcm
800	(3) — #3/0 AWG-500 mcm
1200	(4) — #3/0 AWG-500 mcm

Branch Switch Connectors

Switch Ampere Rating	Wire and Cable Range
30	(1) — #14-#4 AWG (Cu or Al)
60	(1) — #14-#4 AWG (Cu or Al)
100	(1) — #10-#1/0 AWG (Cu or Al)
200	(1) — #6 AWG-350 kcmil (Cu or Al)
400	(2) — #4/0 AWG-500 kcmil (Cu or Al)
600	(2) — #4/0 AWG-500 kcmil

Maximum VB HP Ratings

Amp Rating	3 Phase			Single Phase	DC
	Volts			Volts	Volts
	240	480	600	240	250
30	7.5	15	20	3	5
60	15	30	50	10	10
100	30	50	50	15	20
200	50	—	—	—	40
400	—	—	—	—	50

Maximum VK HP Ratings

Amp Rating	3 Phase			Single Phase	DC
	Volts			Volts	Volts
	240	480	600	240	250
30	7.5	15	20	3	5
60	1.5	30	50	10	10
100	30.0	50	75	15	20
200	60.0	125	150	15	40

Main Lug Panels

Ampere Rating	Connectors Suitable for Cu or Al
400 [®]	(1) — #3/0 AWG-500 mcm (2) — #3/0 AWG-250 mcm
600	(2) — #3/0 AWG-500 mcm
800	(3) — #3/0 AWG-500 mcm
1200	(4) — #3/0 AWG-500 mcm

Gutters

Ampere Rating	End Gutters (Minimum inches)	Side Gutters (Minimum inches)
400	12	7.9
600	12	7.9
800	12	7.9
1200	12	7.9



Sentron® Panelboards

SELECTION

Power and Distributions

Type F2 (FPP6)

Maximum Panel Ampere	Unit Space (MLO)	Box Height				
400A	30"	60"	120/240Volts 1 Phase, 3 Wire	120/208 Volts 3 Phase, 4 Wire	600 Volts 3 Phase, 3 Wire	347/600 Volts 3 Phase, 4 Wire
600A	45"	75"				
800A	60"	90"				
1200A						

Branch Switches 600V Maximum^①

Rating Ampere	Maximum Voltage	Fusing (1)	Mounting Height F2 38" W
30/30A (VK)	600V	J, C	6.25(159)
60/60A (VK)		J, C	6.25(159)
100/100A (VK)		J, C	7.5(190)
200A (VB)		J, Code, R	10(254)
200/200A (VK)		J	10(254)
400A (VB)		J, Code, R,T	15(381)
600A (VB)		J, Code, R,T	15(381)

Switch Lug Sizes

Switch Rating Ampere	Wire and Cable Range
30	1 - #14-4 Awg (Cu or AL)
60	1 - #14-4 Awg (Cu or AL)
100	1 - #10-1/0 Awg (Cu or AL)
200	1 - #6 Awg-350 MCM (Cu or AL)
400	2 - #4/0 Awg-500 MCM (Cu or AL)
600	2 - #4/0 Awg-500 MCM (Cu or AL)

Fuse Clip provisions per unit

Class R	Class T
Rating Ampere	Rating Ampere
30	30
60	60
100	100
200	200
400	400
600	600

PANELBOARDS

① Single or twin units as listed and are valid for class C or J fuses. If class R or T fuse provisions are required add per table above.
 ② Not applicable to VB style units 400A and 600A.

③ Use of auxiliary switch kit will require the use of a 7.5" (190) high unit for 30 and 60 Amp. switches.
 ④ Refer to Siemens for single phase and DC horsepower requirements.

⑤ Ratings are based on UL test procedure. CSA will not recognize ratings above 100Hp.

Modifications and Additions

Type F2 (FPP6)

When required, special constructions or additions to standard panelboards may be specified for all **factory-assembled** Power and Distribution Panelboards. Below and on the next page are listed many of those available, for Type F2 panelboards. In no case do these apply to **Narrow** (Column) Width Lighting Panelboards.

1. Miscellaneous

NEMA TYPE
Type 1
Type 2 (Drip-proof)
Type 3R
Type 12

2. Painted Finish

Description
Touch-Up Paint (ASA61, Light Gray) 12 oz. aerosol can, Catalog Number TUP-61

3. Miscellaneous Accessories

Nameplate — laminated, engraved Tamper-Proof Screws
--

4. Devices Mounted on Gutter Cover Includes Device, Mounting — Wired or Unwired

Description
Toggle Switch — SPST or 3-way; 15A
Pilot Light — General Purpose, Neon or Incandescent
Pushbutton

5. Grounding of Panelboards^③

Non-Insulated Equipment Ground Bus Including Ground Lug
Insulated Equipment Ground Bus Including Ground Lug

6. Remote Control Switches^④ 600V AC

600V AC Ampere Rating	ASCO 920 Mechanically Held ^{⑤⑥}		Siemens CLH Electrically Held ^⑦	
	2-Pole	3-Pole	2-Pole	3-Pole
30	Unit space 20"		Unit space 20"	
60				
75				
100				
150 ^⑤				
200 ^⑤				
225				

7. Increased Capacity Neutral

Ampere Rating		Unit Space (inches)
Phase	Neutral	
400	600	None
400	800	None
600	1200	None
800	1200	None

8. Main Bus

Standard main bus and ground bus is tin plated aluminum. For copper main bus, neutral bus and ground bus change prefix 'A' to 'C' on catalog number and contact your sales office for pricing.

9. Copper Lugs — For Main Lug Only Panels

Standard main lugs and neutral lugs are tin plated aluminum, UL & CSA listed for use with aluminum/copper cables. For copper Lugs in the mains and neutral for use with copper cables only, contact sales.

10. Feed-Through Lugs^① (One Set Per Panel)

Ampere Rating	Unit Space (Additional inches)	
	3-Pole	2-Pole MLO
400	Consult Sales	10
600		10
800		17.5
1200		17.5

11. Split Bus (Aluminum)^②

Number of Poles	Unit Space (Additional inches)			
	400A	600A	800A	1200A
2	Consult Sales			
3				

12. MLO Compression Lugs

Available as main lugs and neutral lug.

Ampere Rating	Aluminum (Specify Size)	Copper (Specify Size)	Deduct From Available Unit Space (inches)
600	Consult Sales	Consult Sales	5
800		5	
1200		5	

13. VK Switch Accessories

Item	Cat. No.
Fuse Pullers (2) 30/60 mp	FP2
100 amp	FP3
200 amp	FP4

14. Sentron TPS (TVSS Modules)

160 KA
240 KA
Options Surge Counter Remote Indicator

① For use on main lug, main breaker or main switch panels without subfeed breakers.
② For increase in panelboard height — Consult local sales office.
③ Ground bar is not installed in box.
④ For required unit space — consult local sales office. Price includes increased enclosure height if required.
⑤ Devices listed by Underwriters' Laboratories, Inc. When 2 wire control is required. Relay and Terminal Block (9" of unit space required).

⑥ For short circuit ratings with remote control switches consult sales office.
⑦ Panelboard short circuit rating is limited to 5,000 RMS symmetrical.

Sentron® Panelboards

SELECTION

Modifications, Additions Replacements for Fusible Switches

Replacement Units^①

Amperes Rating	250 Volts® Code Fuses Cat. No.	600 Volts® Code Fuses Cat. No.	600 Volts J Fuses Cat. No.	600 Volts R Fuses Cat. No.	600 Volts T Fuses Cat. No.	600 Volts C Fuses Cat. No.	Height in (mm)
----------------	--------------------------------	--------------------------------	----------------------------	----------------------------	----------------------------	----------------------------	----------------

VK Switch For Use With FPP6 Panelboards^{②③}

30/30	N/A	N/A	VK23611JP	VK23611RP	N/A	VK23611CP	6.25 (159)
60/60	N/A	N/A	VK23622JP	VK23622RP	N/A	VK23622CP	6.25 (159)
100/100	N/A	N/A	VK33633JP	N/A	VK33633TP	VK33633CP	7.5 (90)
200/200	N/A	N/A	VK73644JP	N/A	VK73644TP	N/A	10 (254)

VB Switch For Use With VB6 Panelboards

30/30	N/A	N/A	V7E3611JP	N/A	N/A	N/A	7.5(190)
60/60	N/A	N/A	V7E3622JP	N/A	N/A	N/A	7.5(190)
100/100	N/A	N/A	V7E3633JP	N/A	N/A	N/A	7.5(190)
200	V7F3204CP	V7F3604CP	V7F3604JP	V7F3604RP	N/A	N/A	10(254)
400	V7H3205CP	V7H3605CP	V7H3605JP	V7H3605RP	V7H3605TP	N/A	15(381)
600	V7H3206CP	V7H3606CP	V7H3606JP	V7H3606RP	V7H3606TP	N/A	15(381)

Connecting Strap Kits

Rating Amperes	VB Switch VB6® Cat. No.	VK Switch Series 6 Cat. No.
30/30 60/60 100/100	VB6-71	VK6-57 VK6-57 VK6-58
100 200/200 200 400-600	VB6-71 N/A VB6-71 VB6-150	N/A VK6-72 VK6-71® N/A

Panelboard

Tub Width	Depth	Panel Type	Replacement Max Amps	Note
30" - 36" - 42"	9"	OLD CDP	400	MCCB only. Use 5939 series connectors
	9.75"	OLD CDP	600	MCCB only use 5939 series connectors Refer for 800/1200A MCCB's
32" - 38"	13.75"	CDP/VB6	1200A	MCCB series 6 connectors
			600A	"VB" style units only (*)
38"	12.75"	SPP/FPP6	1200A	MCCB series 6 connectors
			600A	"VK" or "VB" style (*)

Blank Plates®

For use with Series 6 CDP Panelboards, S5, F2, FCI and FCII Switchboards.

Height	SPP/FPP/CDP/VB 6
1.25"	6FPB01
2.50"	6FPB02
3.75"	6FPB03
5.00"	6FPB05
10.00"	6FPB10
15.00"	6FPB15

①-For Series 6 Main Devices above 200A, add suffix MS to Catalog Number when ordering.

②-When 2-Pole units are required, use 3-Pole.

③-Series 6 (VB6, CDP6) replacement units and connector kits also accommodates FCI and FCII distributions interiors. Units installed after October 1991 will be FPP6 type.

④-Refer to Siemens for units equipped with auxiliary switches.

⑤-Price is for two brackets – to be included with filler plates.

⑥-To be used in tubs with 30-200A, VB units or fillers in 12¹/₈" deep tub.

⑦-Can be used as fillers or in place of circuit breakers, VK or VB Switches.

⑧-Special order